

HITACHI
Inspire the Next

WJ-C1

Compact high-performance inverter

NEW

Creating the Future with Easy Operation and Smart Control

The Right Drive to Succeed



The Right Drive to Succeed



HITACHI Inverter WJ series C1

Global support

Support to improve
operating effectiveness

Support for cost reductions

Support for stable
operation of equipment

Support for Green
Transformation

Global support

Support for various communication protocols and corresponds to the international standards.

Support for various communication protocols

Various communication protocols are supported, while network support, and external ports are available. Modbus-RTU(RS485) communication remains as standard.

Following fieldbus networks are available with option boards.

CC-Link, EtherCAT, PROFIBUS-DP, PROFINET.



*The communication option supporting CC-Link, EtherCAT, PROFIBUS-DP, PROFINET can be used only in the basic mode.
 *EtherCAT® is registered trademark and patented technology, licensed by Beckhoff Automation GmbH, Germany. PROFIBUS® and PROFINET® are registered trademarks of PROFIBUS Nutzerorganisation e.V.(PNO). CC-Link® is a registered trademark of Mitsubishi Electric Corporation. Other company names and product names mentioned are the property of the respective trademarks or registered trademarks.

"High quality" to comply international standards

Corresponds to the EU Directive, UL and cUL. Complying with the RoHS2.

Corresponds to the EU Directive, UL and cUL in order to guarantee the quality and safety. The quality is recognized in Europe and the United States.

EU Directive	LVD	: EN 61800-5-1
	EMC directive	: EN IEC 61800-3
	RoHS2 directive	: EN IEC 63000
	Machinery directive	: EN ISO13849-1/ (Functional Safety) EN 61800-5-2/ EN 61508
UL	Power Conversion Equipment/UL61800-5-1	

A noise filter is required for complying of EMC directive.



Complying with the RoHS2.

This product complies with EU RoHS2, which restricts the use of hazardous materials.

Complying with the RoHS2.

This product complies with EU RoHS2, which restricts the use of hazardous materials.

CONTENTS

Features P.1-8

Model configuration/
Standard Specifications P.9-10

Common specifications P.11

Dimensions P.12

Terminals P.13-14

Operation P.15

Protective Functions P.16

Connecting Diagram P.17

Connecting to PLC P.18

Wiring and Accessories P.19

Differences from WJ200 P.20

Communication Option P.21-22

Current Derating P.23-24

For Correct Operation P.25-26



JQA-1153
JQA-EM6974

Hitachi Industrial Equipment Systems Co., Ltd.
NARASHINO division is certified for ISO 14001 (standard of environmental management system) and ISO 9001 (standard of quality assurance management system).

Support to improve operating effectiveness

We have improved our maintenance free design with features such as our new jog dial and simple copying and conversion of parameters of our prior design.



JOG dial facilitates parameter setting process

From conventional \triangle / ∇ button to new JOG dial. Parameter can be set smoothly and intuitively.



You can set the parameter smoothly with a single finger, and you can set all functions easily.

Operation example

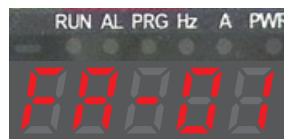

Output frequency setting (Monitor)

Select an output frequency command to the motor (min. frequency to max. frequency (Hz)).



SET key

Press SET key to determine parameter.

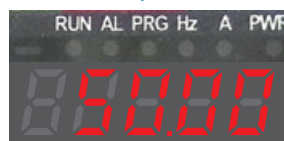

Select a frequency with JOG dial.



SET key

Press SET key to determine parameter. You can adjust frequency as if you were operating a volume knob on audio equipment.

Preventative Maintenance Advance Notification

Inverter diagnostic



Actual operation data can be monitored to predict the degree of power modules cycle degradation (approximate). In addition to the lifetime assessment of capacitors and cooling fans of our WJ200, a lifetime assessment of power modules is installed in the new WJ series C1 (Afterward "WJ Series C1" referred as WJ-C1.) Preventative maintenance is realized by lifetime assessment of components. This function can prevent system downtime in production line, or essential operations.

Example of system diagnostic

The data shows that the degradation is more quickly than expected, and it notifies the appropriate replacement timing.

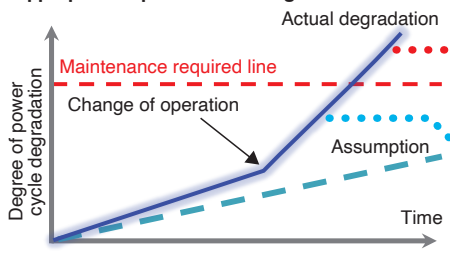

If parts is not replaced...

The system goes down and the production line stops.

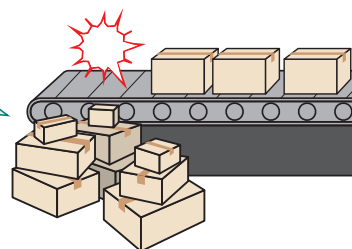

The stable system operation is realized by lifetime assessment of component in advance.

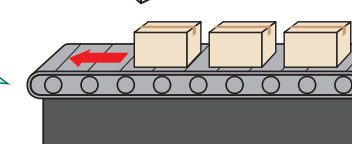

version UP Improvement or added item from WJ200.

NEW functions New functions of WJ-C1.

Familiar size and design for easy replacement

Direct replacement becomes easy as installation area or footprint of WJ200 and WJ-C1 are the same.



Two selectable modes

version UP

In addition to the newly added multi-function "extended mode" normally found in the SJ series P1, the WJ-C1 also has "basic mode" equivalent to the WJ200. The operation mode of WJ-C1 can be selected from the extended mode and the basic mode. Moreover, the optional remote operator WOP enables copying parameter settings from WJ200 to WJ-C1 (extended mode) while converting parameters to the new format.

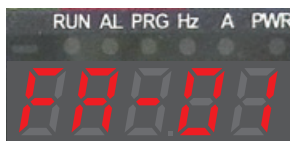

*Remote operator VOP is required to read parameters of WJ-C1 (extended). Some functions are Limited in basic mode. Factory default is extended mode.

Extended mode (5 digit)

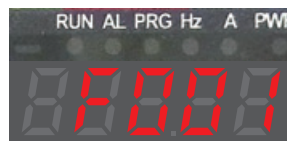

Basic mode (4 digit)



Combination of copy			Operator
WJ200 WJ-C1 (Basic mode)	→ Convert →	WJ-C1(Extended mode)	WOP 
WJ200 WJ-C1 (Basic mode)	→ Copy →	WJ-C1(Basic mode)	
WJ-C1(Extended mode)	→ Copy →	WJ-C1(Extended mode)	VOP 

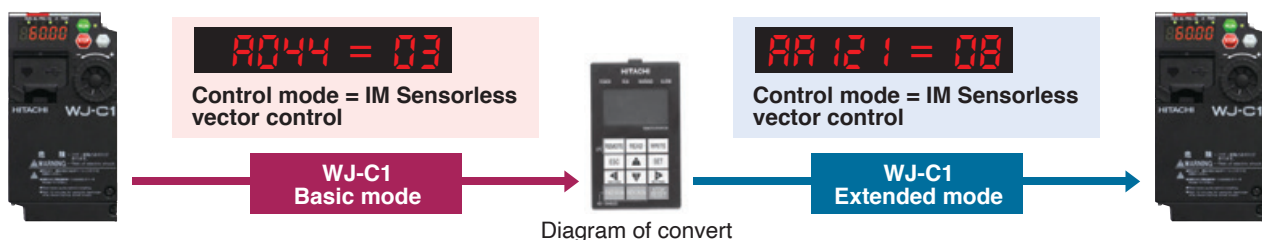

Support to improve operating effectiveness

You can conveniently simulate applications and set parameters without the need of power source.

Parameters can be set prior to installation by 24VDC control power supply.

In addition to the normal power supply, WJ-C1 can be operated by supplying an external 24VDC. Parameter setting can be done before going on site because WJ-C1 can be operated without the main power supply. Therefore, installation time on site can be shortened and operational efficiency increased. You can also connect to a PLC to program or operate using the PC Setting Software (ProDriveNext).

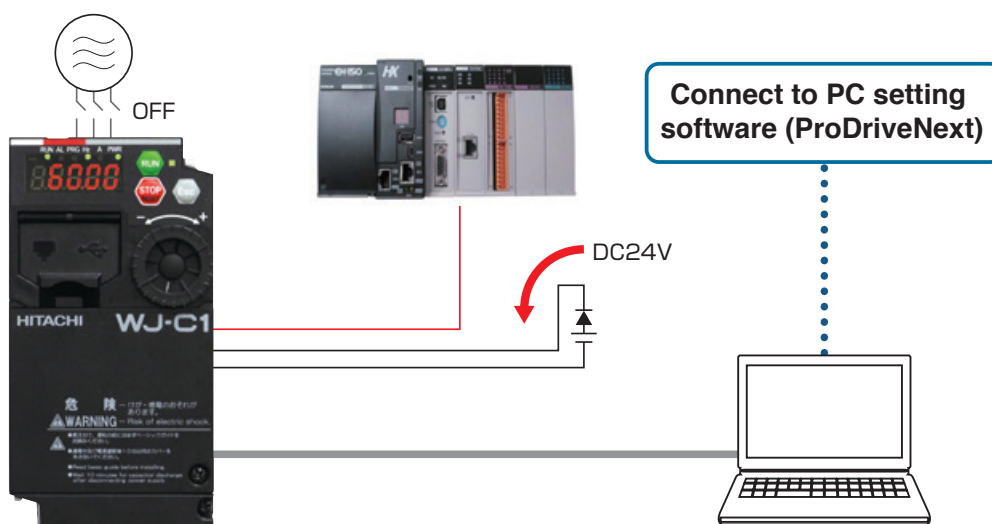

Simulation function reduces test run time

NEW
functions

This function shuts off only the motor output while each inverter function is enabled. Parameters and analog inputs can be used to set virtual output current, etc. to verify the operation of the host device in the event of an alarm without a motor.

Simulation can be performed without running the motor.

Shuts off output to the motor in simulation mode.

Simulation mode can set virtual output torque, etc.



Support for cost reductions

Functions such as simple vector control and multiple PID can reduce the cost of the host device.

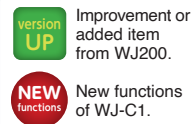

Simple vector control without the need for optional board

version UP

WJ-C1 can use simple vector control without an additional optional board.

It supports IM motor sensorless vector control and V/f control. The WJ-C1 can calculate and compensate the speed deviation from internally calculated speed sensor data in real time while improving torque characteristics.

Example: V/f control



Commands to the motor.



When the inverter outputs frequency and voltage commands to the motor, if a load of the motor is large, the speed will be delayed.

Example: Simple vector control



Commands to the motor.

Check the operation status of the motor.

The command is output again so that the target speed is reached.



The inverter checks the operation status of the motor in simple vector control. The command is output again so that the target speed is reached, and no delay is generated.

Target speed

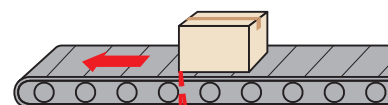

V/f control
A speed delay occurs.

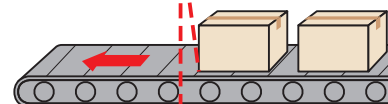

Simple vector control

Correcting speed delay in real time.

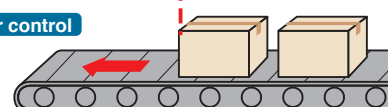

Reduction of system hardware cost by multiple PID function

version UP

WJ-C1 has two PID loop controllers. The inverter controls the operation of the motor with PID controller, and an external device can also be controlled independently with another PID controller.

Therefore, WJ-C1 can control the motor and the external device without a host device, such as a PLC.

Example: Inverter control of pump flow rate + temperature control of heater

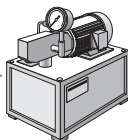

Pump

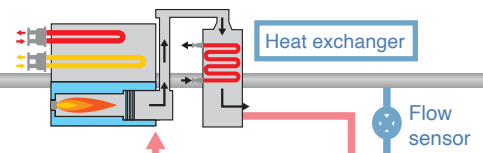

Heat exchanger

Flow sensor

Temperature sensor

Waveform can be checked by trace function without measuring instruments

NEW functions

This function visualizes the sampling data of parameters selected by an operator.

The operator can then check the status of WJ-C1 by checking waveform at "trip" without additional or external measuring instruments.

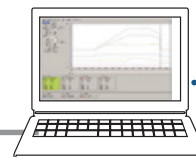

Pay attention to the specification difference from the assumed measuring instrument.

※PC software (ProDriveNext) for inverter-setting is required to check the data. Please contact the supplier where this device was purchased or local Hitachi inverter sales office to get PC software(ProDriveNext).

Support for stable operation of equipment

Supports the stable operation of the system with inverters which is certified "functional safety SIL3" as standard.

Certified "functional safety SIL3" as standard

version
UP

Supports the stable operation of the system with inverter that is certified functional safety SIL3.

This product complies with international standards for the construction of safety systems in standard specifications.

- EN ISO13849-1:Cat.3 PLe
- EN 61800-5-2, EN 61508:SIL3

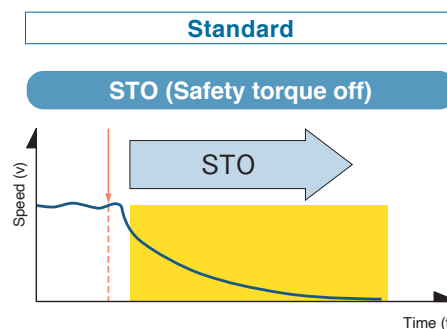
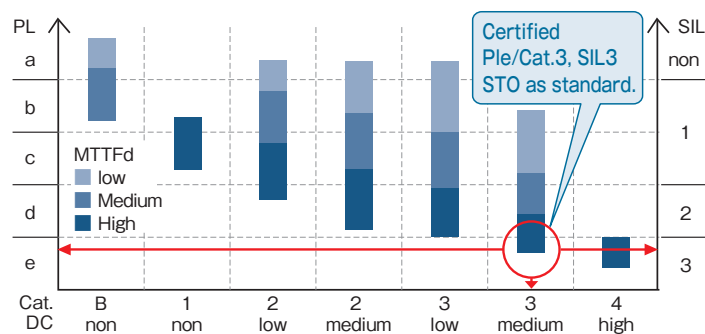

WJ-C1 can assist on the stable operation of a system by detecting "Unusual state" conditions.

Non-steady
detection

NEW
functions

This function can detect abnormalities such as a clogged pipe and belt rip. The function prevents problems in production, or operations while it contributes to notify operations and stabilize functional deviations.

Output current and other monitor data are monitored by the inverter, to detect conditions that differ from the steady state without a sensor. Alarms and warnings are issued to detect a sign of a failure without using a host device or a sensor.

WJ-C1 detects and notifies a failure on the production line.

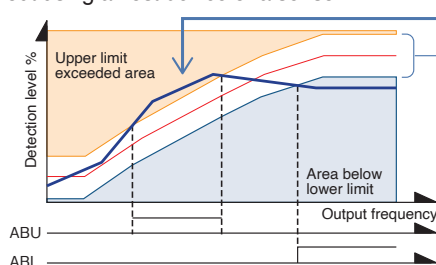

WJ-C1 can detect that a monitored parameter is not in the expected area.

The desired range can be set for the expected area.

Easy to use simple positioning control

version
UP

The pulse-speed can be detected up to 32kHz, thus the WJ-C1 can control the motor by simple positioning over a wider range than the WJ200.

WJ-C1 also is equipped with the simple position control (when using feedback-signal). This function of WJ200 received good reviews from end users. Speed control operation and position control operation can be selected. While the input terminal is turned on, the current position counter is 0. If the terminal is turned off during operation, position control operation starts from when the terminal is turned off. (Speed/position switching)

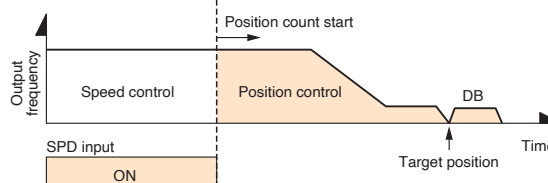

Support for Green Transformation

"Green Transformation (GX)" is indispensable initiative to achieve economic growth while resolving environmental issues. We are contributing to the global initiative to achieve carbon neutral status.

version UP
Improvement or added item from WJ200.

NEW functions
New functions of WJ-C1.

Energy saving by PM motor

version UP

WJ-C1 is equipped with both control functions for induction motor and PM motor. The controller can be re-parametrized when replacing an induction motor with a PM motor. In addition, the new overcurrent-level setting function prevents a demagnetizing of PM motor due to overcurrent.

Overcurrent level adjustment

The overcurrent trip level can be adjusted by parameters.

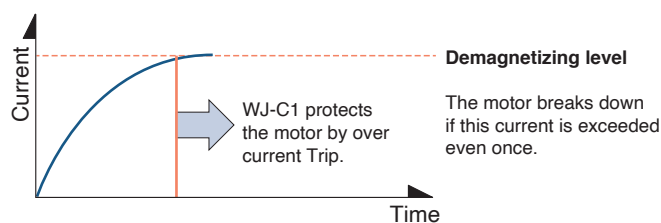

PM motors that contribute to energy conservation

PM motors are more efficient than induction motors, contributing to energy savings. Energy measures will help to reduce costs, while at the same time resolving global environmental issues.

Traditional controller

Management of each controller is required.

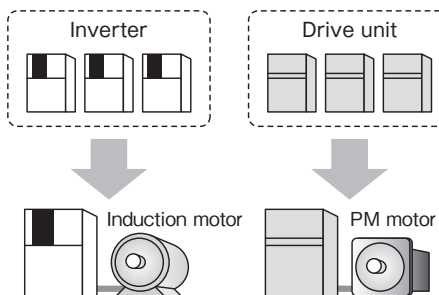

WJ-C1

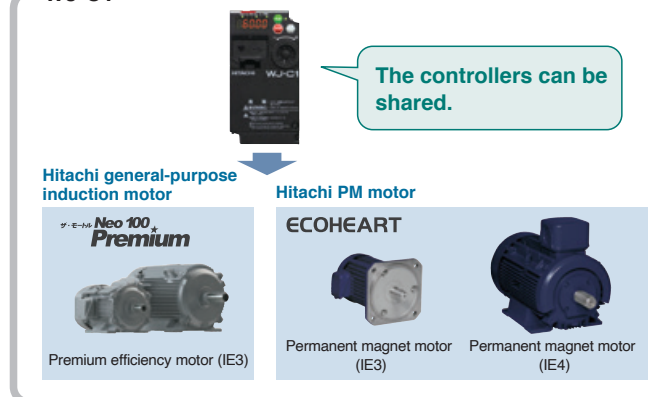

*Since the operation differs from that of WJ200 such as the frequency matching function, it needs to be verified on the actual device.

●When using PM sensorless vector control, contact your dealer.

First step toward environmental measures: Use of recycled resin

Decarbonization is becoming an urgent issue around the world, Hitachi Industrial Equipment Systems is working to become carbon neutral in various businesses. WJ-C1 takes the first step toward realizing a recycling-oriented society by using recycled resin for its outer housing.



Model configuration

• WJ series C1 model name indication

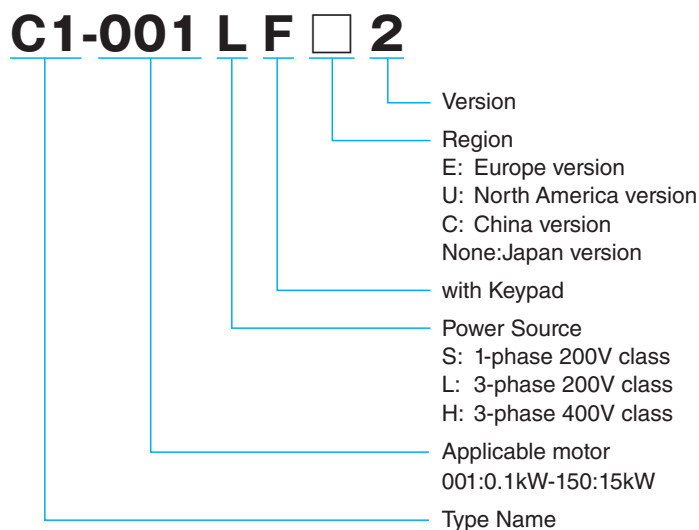

• Lineup

Applicable motor (kW)	0.1	0.2	0.4	0.75	1.5	2.2	3.0	3.7	4.0	5.5	7.5	11	15
1-phase 200 V (ND rating)	●	●	●	●	●	●							
3-phase 200 V (ND rating)	●	●	●	●	●	●		●		●	●	●	●
3-phase 400 V (ND rating)			●	●	●	●	●		●	●	●	●	●

(Note) The applicable motor refers to Hitachi standard 3-phase motor (4-pole) except 400V class 3.0kW and 4.0kW.
To use other motors, be sure to prevent the rated motor current from exceeding the rated output current of the inverter.

Standard Specifications

• Single phase 200V class

Model name ^{*1} (C1- <input type="checkbox"/> <input type="checkbox"/> <input type="checkbox"/> SF <input type="checkbox"/> 2)			001	002	004	007	015	022	
Motor ^{*2}	kW	LD	0.2	0.4	0.55	1.1	2.2	3.0	
		ND	0.1	0.2	0.4	0.75	1.5	2.2	
	HP	LD	1/4	1/2	3/4	1.5	3	4	
		ND	1/8	1/4	1/2	1	2	3	
Rated capacity (kVA)	Basic	200V	LD	0.4	0.6	1.2	2.0	3.3	4.1
			ND	0.2	0.5	1.0	1.7	2.7	3.8
		240V	LD	0.4	0.7	1.4	2.4	3.9	4.9
			ND	0.3	0.6	1.2	2.0	3.3	4.5
	Extended	200V	LD	0.4	0.7	1.2	2.0	3.4	4.2
			ND	0.2	0.5	1.1	1.7	2.7	3.8
		240V	LD	0.5	0.8	1.4	2.4	4.0	5.0
			ND	0.3	0.6	1.3	2.0	3.3	4.5
Rated input voltage (V)			Single phase 200V to 240V(-15%/+10%), 50/60Hz ± 5%						
Rated output voltage (V) ^{*3}			Three phases 200 to 240V						
Rated output current (A)	Basic	LD	1.2	1.9	3.5	6.0	9.6	12.0	
		ND	1.0	1.6	3.0	5.0	8.0	11.0	
	Extended	LD	1.3	2.0	3.5	6.0	9.8	12.2	
		ND	1.0	1.6	3.2	5.0	8.0	11.0	
Braking torque	Regenerative braking		Built-in regenerative braking circuit (Separate discharge resistor)						
	Minimum braking resistor (Ω)		100			50		35	
Cooling method			Self-cooling				Force ventilation		
Weight (kg)			1.0	1.0	1.1	1.6	1.8	1.8	

*1 The part of the model's name indicates an applicable motor capacity at ND rating.

*2 LD: Light Duty, ND: Normal Duty(Dual rating).

Applicable motors are Hitachi's three-phase standard motors (4P), which are standard lineup of Hitachi.

When use other manufacturer motors, be sure to not exceed a rated current of a motor the rated output current of the inverter.

*3 The output voltage cannot exceed the actual input voltage (Main power supply voltage).

Standard Specifications

• Three phases 200V class

Model name ^{*1} (C1- □□□ LF □ 2)			001	002	004	007	015	022	037	055	075	110	150	
Motor ^{*2}	kW	LD	0.2	0.4	0.75	1.1	2.2	3.0	5.5	7.5	11	15	18.5	
		ND	0.1	0.2	0.4	0.75	1.5	2.2	3.7	5.5	7.5	11	15	
	HP	LD	1/4	1/2	1	1.5	3	4	7.5	10	15	20	25	
		ND	1/8	1/4	1/2	1	2	3	5	7.5	10	15	20	
Rated capacity (kVA)	Basic	200V	LD	0.4	0.6	1.2	2.0	3.3	4.1	6.7	10.3	13.8	19.3	23.9
			ND	0.2	0.5	1.0	1.7	2.7	3.8	6.0	8.6	11.4	16.2	20.7
		240V	LD	0.4	0.7	1.4	2.4	3.9	4.9	8.1	12.4	16.6	23.2	28.6
			ND	0.3	0.6	1.2	2.0	3.3	4.5	7.2	10.3	13.7	19.5	24.9
	Extended	200V	LD	0.4	0.7	1.2	2.0	3.4	4.2	6.7	10.3	15.6	20.7	24.2
			ND	0.2	0.5	1.1	1.7	2.7	3.8	6.0	8.6	11.6	16.2	21.6
		240V	LD	0.5	0.8	1.4	2.4	4.0	5.0	8.1	12.4	18.7	24.9	29.1
			ND	0.3	0.6	1.3	2.0	3.3	4.5	7.2	10.3	13.9	19.5	26.0
Rated input voltage (V)			Three phases 200V to 240V(-15%/+10%), 50/60Hz ± 5%											
Rated output voltage (V) ^{*3}			Three phases 200 to 240V											
Rated output current (A)	Basic	LD	1.2	1.9	3.5	6.0	9.6	12.0	19.6	30.0	40.0	56.0	69.0	
		ND	1.0	1.6	3.0	5.0	8.0	11.0	17.5	25.0	33.0	47.0	60.0	
	Extended	LD	1.3	2.0	3.5	6.0	9.8	12.2	19.6	30.0	45.0	60.0	70.0	
		ND	1.0	1.6	3.2	5.0	8.0	11.0	17.5	25.0	33.5	47.0	62.5	
Braking torque	Regenerative braking		Built-in regenerative braking circuit (Separate discharge resistor)											
	Minimum braking resistor (Ω)		100			50			35		20		17	
Cooling method			Self-cooling					Force ventilation						
Weight (kg)			1.0	1.0	1.1	1.2	1.6	1.8	2.0	3.5	3.5	4.5	6.5	

*1 The part of the model's name indicates an applicable motor capacity at ND rating.

*2 LD: Light Duty, ND: Normal Duty (Dual rating).

Applicable motors are Hitachi's three-phase standard motors (4P), which are standard lineup of Hitachi.

When use other manufacturer motors, be sure to not exceed a rated current of a motor the rated output current of the inverter.

*3 The output voltage cannot exceed the actual input voltage (Main power supply voltage).

• Three phases 400V class

Model name ^{*1} (C1- □□□ LF □ 2)			004	007	015	022	030	040	055	075	110	150	
Motor ^{*2}	kW	LD	0.75	1.5	2.2	3.0	4.0	5.5	7.5	11	15	18.5	
		ND	0.4	0.75	1.5	2.2	3.0	4.0	5.5	7.5	11	15	
	HP	LD	1	2	3	4	5	7.5	10	15	20	25	
		ND	1/2	1	2	3	4	5	7.5	10	15	20	
Rated capacity (kVA)	Basic	380V	LD	1.3	2.6	3.5	4.5	5.7	7.3	11.5	15.1	20.4	25.0
			ND	1.1	2.2	3.1	3.6	4.7	6.0	9.7	11.8	15.7	20.4
		480V	LD	1.7	3.4	4.4	5.7	7.3	9.2	14.5	19.1	25.7	31.5
			ND	1.4	2.8	3.9	4.5	5.9	7.6	12.3	14.9	19.9	25.7
	Extended	380V	LD	1.3	2.6	3.6	4.6	5.8	7.8	11.5	15.7	20.4	25.0
			ND	1.1	2.2	3.1	3.9	4.7	6.0	9.7	12.5	16.4	21.0
		480V	LD	1.7	3.4	4.5	5.9	7.3	9.8	14.5	19.9	25.7	31.5
			ND	1.4	2.8	3.9	4.9	5.9	7.6	12.3	15.7	20.7	26.6
Rated input voltage (V)			Three phases 380V to 480V (-15%/+10%), 50/60Hz ±5%										
Rated output voltage (V) ^{*3}			Three phases 380 to 480V										
Rated output current (A)	Basic	LD	2.1	4.1	5.4	6.9	8.8	11.1	17.5	23.0	31.0	38.0	
		ND	1.8	3.4	4.8	5.5	7.2	9.2	14.8	18.0	24.0	31.0	
	Extended	LD	2.1	4.1	5.5	7.1	8.9	11.9	17.5	24.0	31.0	38.0	
		ND	1.8	3.4	4.8	6.0	7.2	9.2	14.8	19.0	25.0	32.0	
Braking torque	Regenerative braking		Built-in regenerative braking circuit (Separate discharge resistor)										
	Minimum braking resistor (Ω)		180			100			70			35	
Cooling method			Self-cooling	Force ventilation									
Weight (kg)			1.5	1.8	1.8	1.8	2.0	2.0	3.5	3.5	4.5	4.5	

*1 The part of the model's name indicates an applicable motor capacity at ND rating.

*2 LD: Light Duty, ND: Normal Duty (Dual rating).

Applicable motors are Hitachi's three-phase standard motors (4P), which are standard lineup of Hitachi except 400 V class 3.0 kW and 4.0 kW.

When use other manufacturer motors, be sure to not exceed a rated current of a motor the rated output current of the inverter.

*3 The output voltage cannot exceed the actual input voltage (Main power supply voltage).

Common Specifications

Item	Specifications	
Control method	PWM control	
Output frequency range *1	0.01 to 590.00 Hz	
Frequency accuracy	For the maximum frequency, digital source $\pm 0.01\%$, analog source $\pm 0.2\%$ ($25 \pm 10\text{ }^\circ\text{C}$)	
Frequency resolution	Digital source: 0.01 Hz, analog source: maximum frequency/1000	
Control mode (Frequency and voltage calculation) *2	IM V/f control (constant torque/ reduced torque/ free V/f, automatic torque boost), V/f control with encoder IM sensorless vector control IM sensorless vector control with encoder(Simple vector control)	
	PM(SM/PMM) PM sensorless vector control *3	
Rated overload current	Dual Rating:Nomal Duty (ND): 150% / 60 sec / Light Duty (LD): 120% / 60 sec	
Acceleration/deceleration time	0.00 to 3600.00 sec (linear, curve setting)	
Starting torque *4	200 % of Motor Rated Torque at 0.5 Hz (IM sensorless vector control)	
Carrier frequency range	Nomal Duty (ND):2 to 15kHz Light Duty (LD):2 to 10kHz (with derating)	
Monitor function *5	Output frequency, Output current, Output torque, Trip history, I/O terminal status, Input power, DC voltage, etc.	
Protective function *6	OverCurrent, OverVoltage, UnderVoltage, Electronic thermal, OverLoad and etc.	
Other functions	Free V/f characteristic setting, Manual torque boost, auto-tuning, Simple positioning functons, Energy saving operation, PID control, Brake control, Commercial switching function, Upper and lower speed limit, Speed jump, External start/ end, Analog output adjustment, etc.	
Keypad	5 digits 7 seg, 6 status LED + 1 minus symbol LED, 4 Keys and 1 JOG dial, 1 LED for indicating RUN command source (non-detachable)	
Input	Frequency reference	Keypad, External operator, RS485, Communication option, external analog input
	RUN/STOP command	Keypad, External operator, RS485, Communication option, input terminals
	Input terminals	Terminal [1] to [7] (NO/NC selectable, Sink(PLC-P24 jumper)/Source(PLC-L jumper) selectable) terminal [8] is source logic fixed
	Pulse input	3 terminals max. 32kHz x 3 (terminal [8](when enable phase A), teminal [7](when enable phase B),terminal [6] (when enable phase Z))
	Analog input	2 terminals (terminal [Ai1], [Ai2] for 0 to 10 VDC voltage input and 4 to 20 mA current input selectable
	Thermistor input	1 terminal (shared with terminal [5])(support for PTC type thermistor)
Output	Safety input	2 terminals (terminal [ST1] and terminal [ST2])
	Output terminals	2 terminals with open collector (NO/NC selectable, capable for Sink/Source circuit) 1 terminal for relay output (1c type)
	STO State Monitor Output	1 terminal (shared with terminal [11], switched to EDM by slide switch)
Communication	Analog/Pulse output	2 terminals (terminal [Ao1] for 0 to 10 VDC voltage output / 4 to 20 mA current output selectable terminal [Ao2] for pulse output, max. 32 kHz/ 0 to 10 VDC output selectable)
	USB	Micro-B (for inverter configuration software ProDriveNext)
	RS485	Support for Modbus-RTU*7 (RS-485 serial communication)
	External operator	RJ45 connector (Exclusive connector for remote operator)
Option	Option	WJ200 series field network options. WJ-ECT: for EtherCAT® communication, WJ-PB: for PROFIBUS® communication, WJ-PN: for PROFINET® communication, WJ-CCL: for CC-Link® communication.*7 One unit can be mounted. (except WJ-FS: functional safety option is not supported)
	External control power supply	External 24 VDC can be input from [P24] terminal (installation of reverse-current-prevention diode is mandatory).
EMC noise filter	Not built-in (optional external noise filter can be connected)	
Operating environment	Ambient temperature	ND (normal duty):-10 to 50 °C/ LD (light duty):-10 to 40 °C
	Storage temperature*8	-20 to 65 °C
	Humidity	20 to 90 %RH (non-condensing)
	Vibration	0.075 mm amplitude for 10 to 57 Hz 9.8 m/s ² (1.0 G) for 57 to 150 Hz
	Installation site*9	Altitude: 1000 m or less, indoors (free from corrosive gases, oil mist, dust and effect of radiation)
Structure	Protection: IP20 (UL open type), replaceable Fan	
Standards *10	CE:EN IEC 61800-3:2018 (EMC-filter option required) , EN 61800-5-1:2007, EN 61800-5-1:2007/A1:2017, EN 61800-5-1:2007/A11:2021, EN 61800-9-2:-2017, EN IEC 63000:2018 UL : UL 61800-5-1, 1st Ed., Issue Date 2012-06-08, Revision Date 2021-02-11, -Overvoltage Category 3, -Pollution Degree 2 Others:c-UL C22.2 No.274, 2nd Ed., Issue Date 2017-04-01 Safety function:STO(Safe torque off)function / EN 61800-5-2:2017 : SIL3, EN ISO 13849-1:2015: Cat.3 PLe EN 61508-1 to 7:2010	
Other optional components	Noise Filter, DC link choke, AC reactor, Braking resistor, Regenerative braking unit, External operator (Basic Mode : OPE-SR/OPE-SBK/OPE-SRmini/WOP, Extended Mode: VOP), Inverter configuration software ProDriveNext*11, etc.	

*1 The output frequency range depends on the control mode and the motor used. Consult the motor manufacturer for the maximum allowable frequency of the motor when operating beyond base frequency.

*2 Motor constants might need to be adjusted depending on the control mode.

*3 When using sensorless vector control for permanent magnet motor (PMM), contact your dealer.

*4 The value is specified for the 4 poles Hitachi standard motor controlled by the IM sensorless vector control at ND rating. Torque characteristics may vary depending on the control mode and the motor used.

*5 Monitor function is for reference only. To obtain more accurate values, apply an external device.

*6 When a driver error [E030] occurs due to the protective function, it may be resulted from the short-circuit protection, as well as damaged IGBT. Depending on the operating conditions of the inverter, an overcurrent error may occur instead of a driver error.

*7 Trademark

• Modbus® is a registered trademark of Schneider Electric USA, Inc.

• EtherCAT® is registered trademark and patented technology, licensed by Beckhoff Automation GmbH, Germany.

• PROFIBUS® and PROFINET® are registered trademarks of PROFIBUS Nutzerorganisation e.V. (PNO).

• CC-Link® is a registered trademark of Mitsubishi Electric Corporation.

*8 The storage temperature is the temperature during transportation.

*9 For installation at an altitude of 1000m or more, the atmospheric pressure will decrease by approximately 1% for every 100m altitude increase. Apply 1% current derating from the rated current for every 100m altitude increase and conduct an evaluation test. When using at an altitude of 2500m or more, please contact Hitachi Inverter distributor.

*10 The standards information on the common specifications and this document is as of March 2023.

*11 Recognized as WJ200 in basic mode and WJ-C1 in extended mode.

Dimensions

- C1-001SF□2 to 004SF□2
- C1-001LF□2 to 007LF□2

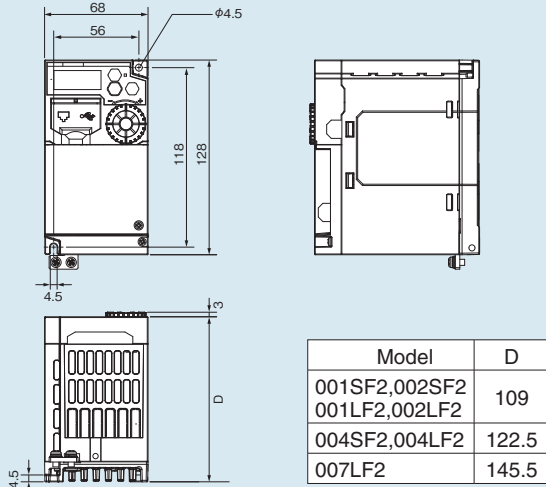

- C1-055LF□2
- C1-075LF□2
- C1-055HF□2
- C1-075HF□2

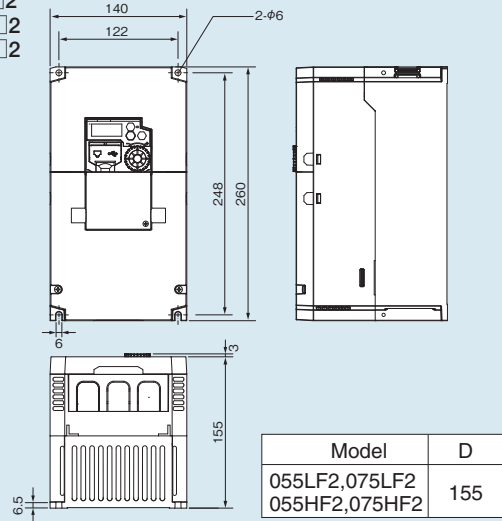

- C1-007SF□2 to 022SF□2
- C1-015LF□2
- C1-022LF□2
- C1-004HF□2 to 030HF□2

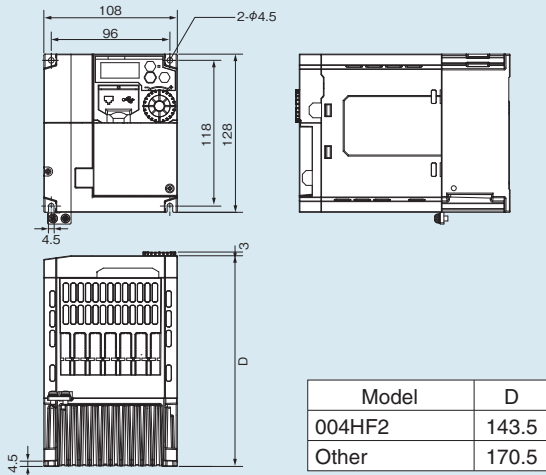

- C1-110LF□2
- C1-110HF□2
- C1-150HF□2

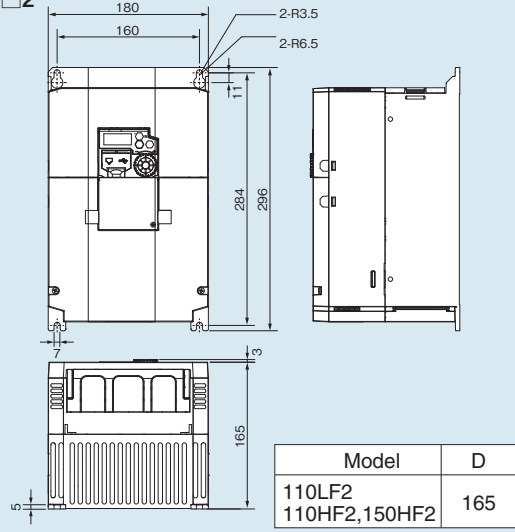

- C1-037LF□2
- C1-040HF□2

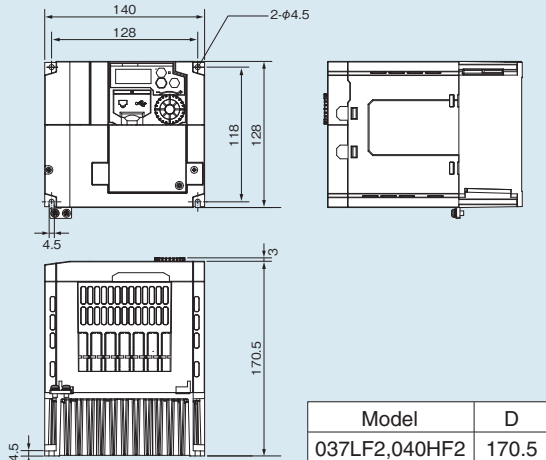

- C1-150LF□2

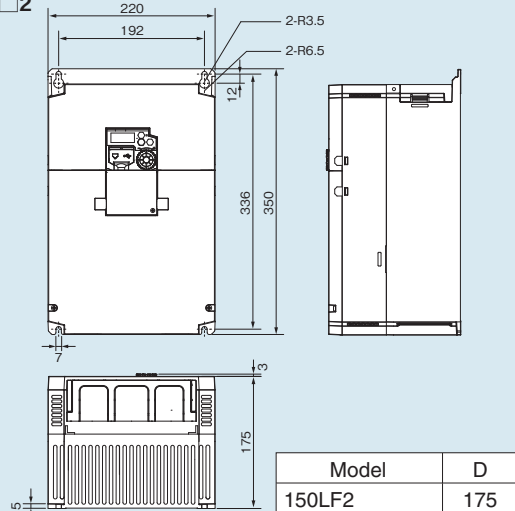

[Unit:mm]

Terminals

Terminal symbol

Terminal symbol	Terminal name
R/L1 (Single-phase: L1), S/L2, T/L3 (Single-phase: N)	Input terminal for main power supply
U/T1, V/T2, W/T3	Inverter output terminal
PD/+1 (Single-phase: +1), P/+ (Single-phase: +)	DC link choke connection terminal
P/+ (Single-phase: +), RB	External braking resistor connection terminal
P/+ (Single-phase: +), N /- (Single-phase: -)	Regenerative braking unit connection terminal
G (⊕)	Inverter ground terminal

Main circuit terminal block arrangement

Models	Screw size	Terminal arrangement
001SF2 to 004SF2, 001LF2 to 007LF2	M3.5	Figure 1
007SF2 to 022SF2, 015LF2 to 037LF2, 004HF2 to 040HF2	M4	Figure 2
055LF2, 075LF2, 055HF2, 075HF2	M5	Figure 3
110LF2, 110HF2, 150HF2	M6	
150LF2	M8	

Terminal Arrangement

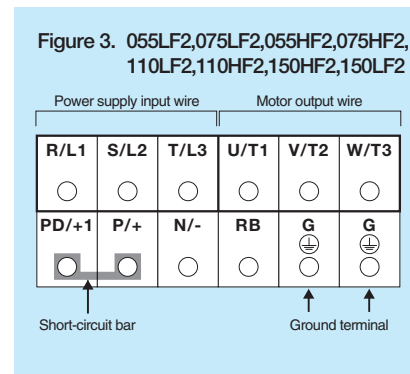
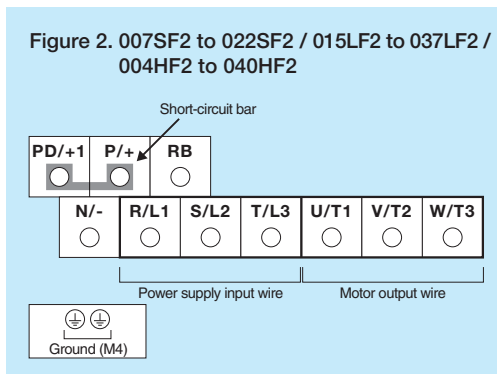
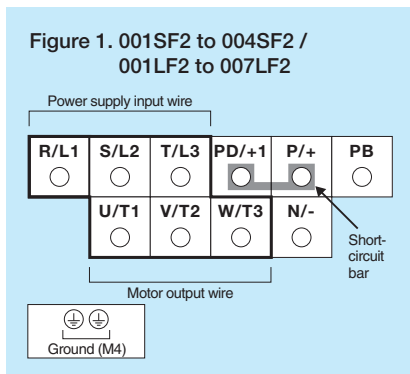

Control circuit terminal block

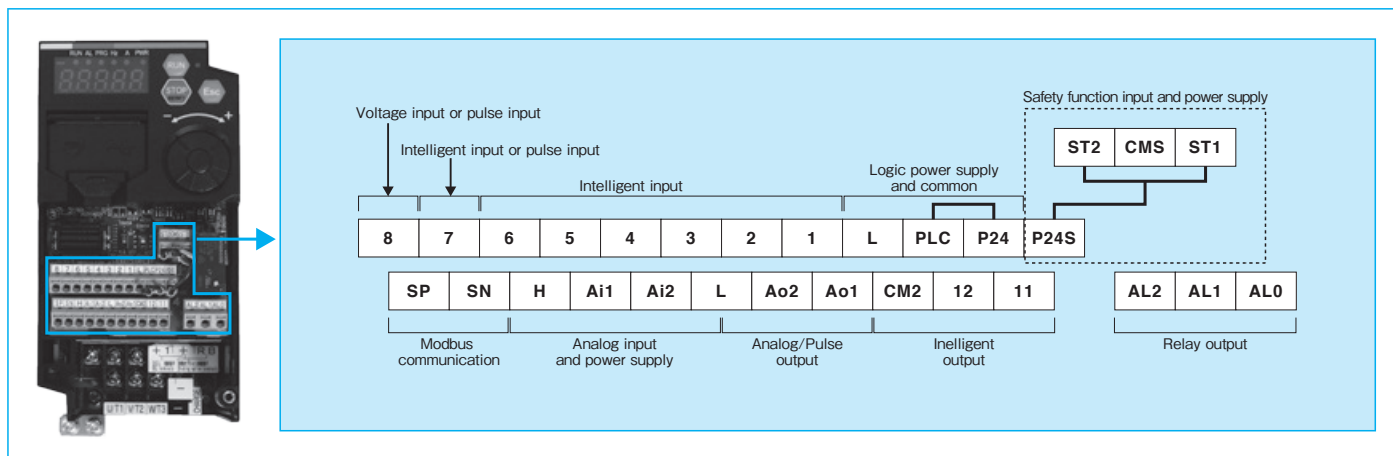

Wiring example of control circuit terminal

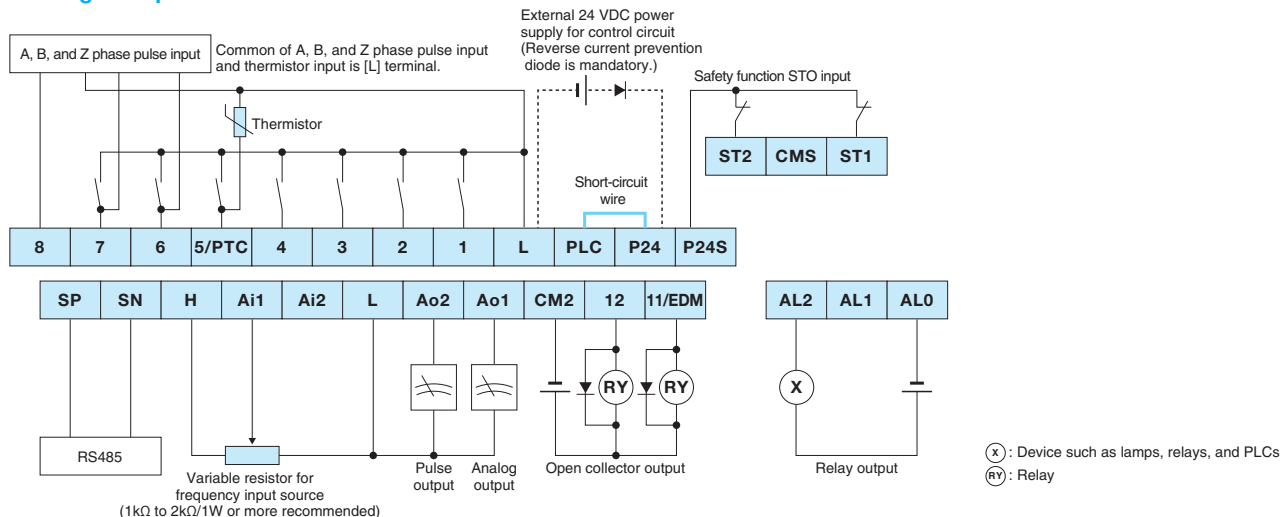

• Terminals symbol

Item	Terminal symbol	Terminal name	Description	Electrical characteristics	
Analog input/output	Power supply	L	Common for input signal	Common terminal for internal power supply, input terminal [1] to [8], analog input/output and pulse output terminals.	–
		H	Power supply for frequency setting	This is a 10 VDC power supply. It is used when using analog input terminals and variable resistor for inputting voltage.	Maximum allowable output current: 10 mA
	Analog input	Ai1	Analog input 1 (Voltage/Current input)	Analog voltage/current input terminals. Analog voltage/current input can be selected for each terminal by parameter setting. - Analog voltage input 0 to 10 VDC voltage input. It is adjusted at the factory to reach the maximum frequency at 9.8 VDC input.	Input impedance: Approx. 10kΩ Allowable input voltage range: -0.3 to +12 VDC
		Ai2	Analog input 2 (Voltage/Current input)	- Analog current input 4 to 20 mA current inputs. It is adjusted at the factory to reach the maximum frequency at 19.8 mA input.	Input impedance: Approx. 100 Ω Allowable input current range: 0 to 24 mA
Thermistor input	5 [PTC]	External thermistor input	When "Thermistor type selection [Cb-40]" set to "PTC (01)", [5] terminal is for external thermistor input. An external thermistor is connected between this terminal and the [L] terminal to trip the inverter due to a temperature error. Regardless of the sink or source logic, the common is the [L] terminal.	PTC type	
Digital input	Power supply	L	Common for input signal	Common terminal for internal power supply, input terminal [1] to [8], analog input/output and pulse output terminals.	–
		P24	Power supply terminal for input signal	24 VDC internal power supply terminal for contact input. Common for source logic input. By supplying external 24 VDC to this terminal, it is possible to operate only the control board and parameters can be read/written. When an external power supply is connected, be sure to connect a reverse current prevention diode.	Maximum allowable current: 100 mA
		PLC	Intelligent input common	Sink logic: short-circuit to [P24] terminal Source logic: short-circuit to [L] terminal When driving the contact input with an external power supply, remove the short-circuit wire. See P18 Connecting the intelligent input terminals to a programmable controller" for more information.	–
	Contact input/ Pulse input	1 2 3 4 5	Intelligent input	Each terminal function can be selected by parameter setting for each terminal. Both sink and source logic are supported. See P18 Connecting the intelligent input terminals to a programmable controller " for more information.	Voltage between each input and [PLC] ON voltage: Min. 18 VDC OFF voltage: Max. 3 VDC Maximum allowable voltage: 27 VDC Load current: 5 mA (at 24 VDC) Internal resistance: 4.7 kΩ
		6	Intelligent input/Pulse input Z	When Z-phase pulse input is required for homing function or home search function, set "Pulse input Z" in "Input terminal [6] function [CA-06]"	Input pulse: Minimum 0.3 Hz to maximum 32 kHz [6]/[7] - [PLC] voltage: ON voltage: Min. 18 VDC OFF voltage: Max. 3 VDC Maximum allowable voltage: 27 VDC Load current: 8 mA (at 24 VDC) Internal resistance: 3.0 kΩ
		7	Intelligent input/Pulse input B/ Direction signal	When "Pulse input, target function selection [CA-90]" is other than "Disable (00)", [7] terminal is for B-phase pulse input or direction command for single-phase pulse input. When [CA-90] is "Disable (00)", [7] terminal is intelligent input terminal.	Input pulse: Minimum 0.3 Hz to maximum 32 kHz [8] - [L] voltage: ON voltage: Min. 4 VDC OFF voltage: Max. 1 VDC Maximum allowable voltage: 27 VDC Internal resistance: 11 kΩ
Digital output	Open collector output	11 12	Intelligent output	Each terminal function can be selected by parameter setting for each terminal. Both sink logic and source logic are supported. See P18 Programmable Controller" for more information.	Open collector output Between each terminal and [CM2] Maximum allowable voltage: 27 VDC Maximum allowable current: 50 mA Voltage drop when turn ON: 4 VDC or less
		CM2	Common for intelligent output	Common terminal for output terminal [11] and [12].	Maximum allowable current: 100 mA
	Relay output	AL0 AL1 AL2	Intelligent relay output	1c contact output. Terminal function can be selected by parameter setting. (The default setting is alarm output.)	Maximum contact capacity [AL1] – [AL0]: 250 VAC 2 A (resistance), 0.2 A (inductive load) 30 VDC 3 A (resistance), 0.6 A (inductive load) [AL2] – [AL0]: 250 VAC 1 A (resistive), 0.2 A (inductive load) 30 VDC 1 A (resistance), 0.2 A (inductive load) Minimum contact capacity 100 VAC, 10 mA 5 VDC, 100 mA
Monitor output	Ao1	Analog output (Voltage/Current output)	Analog voltage/current output terminal. Analog voltage/current output can be selected by parameter setting. - Analog voltage output The monitor value selected by the parameter is output as 0 to 10 VDC. - Analog current output The monitor value selected by the parameter is output as 4 to 20 mA.	In the case of voltage output: - Max allowable output current 2mA - Output voltage accuracy ±10% (ambient temperature: 25°C ±10°C) In the case of current output: - Allowable load impedance 250Ω or below - Output current accuracy: ± 20% (ambient temperature: 25±10°C)	
	Ao2	Analog voltage output /Digital pulse output	Analog voltage/digital pulse output terminal. Analog voltage/digital pulse output can be selected by parameter setting. - Analog voltage output The monitor value selected by the parameter is output as 0 to 10 VDC. - Digital pulse output The monitor value selected by the parameter is output as 10 VDC pulse signal.	In the case of voltage output: - Max allowable output current 2mA - Output voltage accuracy ±10% (ambient temperature: 25°C ±10°C) In the case of pulse output: - Up to 32 kHz - Maximum allowable current: 2 mA	
Serial communication	SP SN	RS485 communication	RS485 ports for Modbus-RTU/EzCOM. To connect the signal ground of the external control device, use [L] terminal.	Maximum baud rate :115.2 kbps Built-in terminal resistance :120 Ω Switched by dip switch SP: RS485 differential (+) signal SN: RS485 differential (-) signal	
Safety Function	P24S	24 VDC output	24 VDC power supply terminal dedicated to [ST1]/[ST2] terminals.	Maximum output current: 100 mA	
	CMS	Common for 24 VDC output	Common terminal for [P24S].	–	
	ST1 ST2	STO input 1 STO input 2	STO input terminal.	[ST1/2] - [CMS] voltage: ON voltage: Min. 15 VDC OFF voltage: Max. 5 VDC Maximum allowable voltage :27 VDC Load current: 5.8 mA (at 27 VDC) Internal resistance: 4.7 kΩ	
	11 [EDM]	STO State Monitor Output	When EDM function switch is turned on, output terminal [11] switches to the EDM signal output terminal.	Open collector output [EDM] - [CM2] Maximum allowable voltage: 27 VDC Maximum allowable current: 50 mA Voltage drop when turn ON: 4 VDC or less	

Operation

Keypad Description

WJ-C1 can be operated easily using the keypad.

LED for unit and status

MINUS: ON while display minus value. (RED)

RUN: ON while the inverter output is active. (GREEN)
Note: ON when the inverter output is ON and while in RUN mode during ramp down. Also, blinks when the inverter is not possible to RUN such when given a 0Hz RUN command.

AL: ON while the inverter trip is active. (RED)

PRG: ON while the inverter is ready for parameter editing. (GREEN) Blinks during warning.

HZ: ON while display frequency data. (GREEN)

A: ON while display current data. (GREEN)

PWR: ON while the power input to the inverter. (GREEN)

RUN key enable LED
ON while the inverter is ready to RUN from RUN key of the keypad. (GREEN)

Key operation

RUN: Is to run the motor from keypad.

STOP/RESET: Is to stop the motor from keypad. / Is to reset a tripped alarm.

Esc: Is to change the function code group or is to cancel the current situation.

JOG dial: Is to move up or down the selection.

SET: Is to confirm the change or is to save the edited parameter.

7 segment LED display (5 digit)
Display each function code and other information such as frequency.

JOG dial

SET

USB connector

RJ45 connector

Function code structure and keypad navigation map. (Extended mode)

The JOG dial operation and navigation map are shown in the figure below.

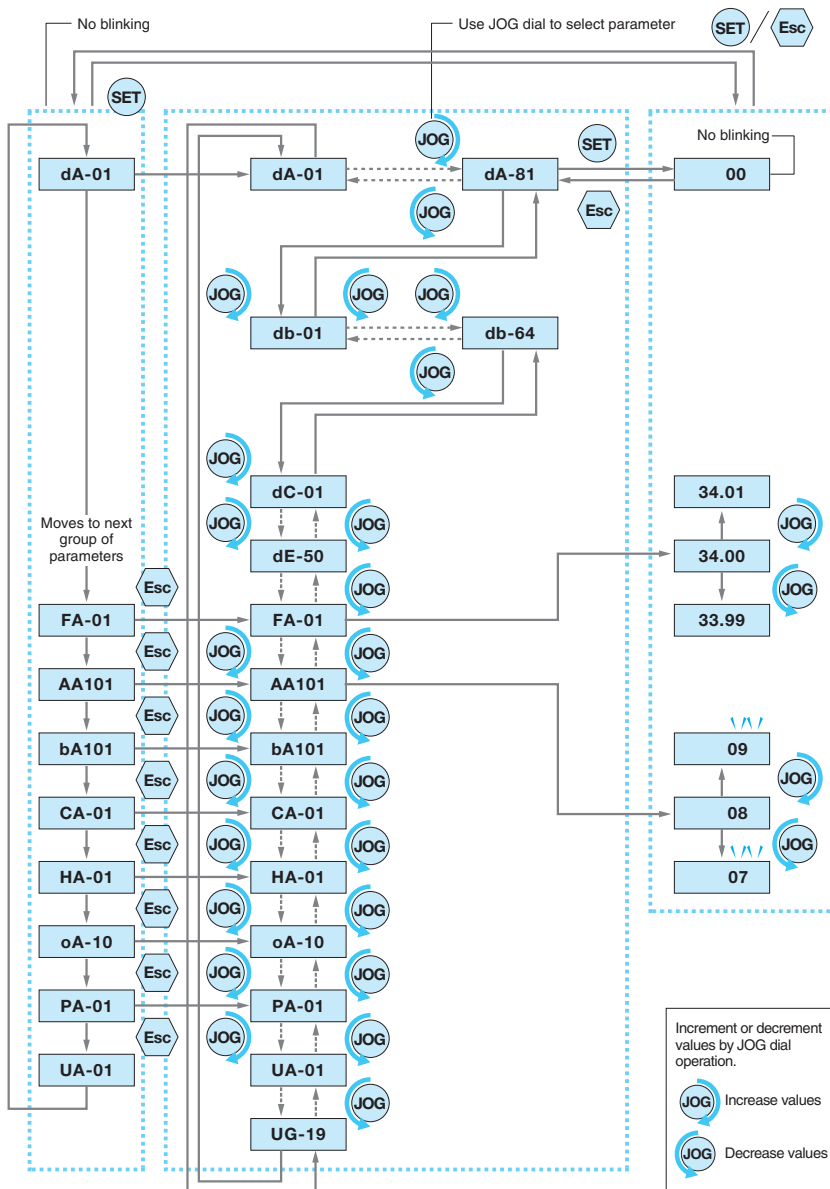

Single-edit mode operation

To use the single-edit mode on WJ-C1, press longer (more than 3 sec.) the SET key. The figure below shows the operation method.

Step 1
Long press (more than 3 sec)

1st digit will be blinking.

Step 2
The blinking digit is moved by the SET and Esc keys right and left. Use JOG dial to change the value of the digit.

Step 3
When the least significant digit is blinking, the SET key selects that parameter.

Protective Functions

Name	Cause(s)	Error Code
Over current error	Shuts off the inverter output and trips, when detecting a large output current exceeding the overcurrent level. Overcurrent level can be set by Overcurrent detection level [bb160]. In factory setting, [bb160] is set to 2.2 times the rated output current at ND rating regardless of ND/LD rating setting. When a large output current exceeding the overcurrent level is detected, the inverter can perform to retry for a certain number of times without tripping by the parameter setting.	E001
Motor overload error *1	Shuts off the inverter output and trips when the electronic thermal function detects a motor overload monitoring the inverter output current. Time until motor overload error and the behavior after motor overload error is changed according to the setting of the motor rated current and the electronic thermal function.	E005
Braking resistor overload error	Shuts off the inverter output and trips, when the braking resistor operation circuit (BRD) usage rate exceeds the usage rate specified in Dynamic brake use ratio [bA-60].	E006
Overvoltage error	Shuts off the inverter output and trips, when detecting a high DC bus voltage exceeding the overvoltage level. Overvoltage level is approx. 400 VDC (200 V class) or approx. 800 VDC (400 V class). When a high DC bus voltage exceeding the overvoltage level is detected, the inverter can perform to retry for a certain number of times without tripping by the parameter setting.	E007
Memory error	Shuts off the inverter output and trips, when the internal memory has problems. CPU error [E011] may be issued instead. The reset operation is not accepted. A power on reset is required. When the inverter recovers by a power on reset, make sure the parameter setting is correct.	E008
Undervoltage error	Shuts off the inverter output and trips, when detecting a low DC bus voltage below the undervoltage level to prevent the temperamental circuit operation Undervoltage level is approx. 173 VDC (200 V class) or approx. 345 VDC (400 V class). When a low DC bus voltage below the undervoltage level is detected, the inverter can perform to retry for a certain number of times without tripping by the parameter setting.	E009
Current detector error	Shuts off the inverter output and trips, when detects abnormally on the built-in current sensor.	E010
CPU error	Shuts off the inverter output and trips, when the internal CPU has problems or malfunction.	E011
External trip	Shuts off the inverter output and trips, when the inverter receive a signal from an external equipment to input terminal which is assigned External fault [EXT].	E012
USP error	Shuts off the inverter output and trips, when the inverter power is turned on while applied an RUN command. Unattended start protection function is valid when input terminal function Unattended start protection [USP] is turned on or [USP] active selection [CA-73] is Enable (01). RUN command detection is executed for 2 second after the power is turned on.	E013
Ground fault error	The inverter instantly protects from ground-fault, when detects the ground fault between the inverter output and the motor on power up. The function does not work while inverter trips. Enable/disable of the ground fault detection can be selected by Detect ground fault selection [bb-64] setting. When the external 24 VDC power supply has been turned on prior to the main power supply (R, S, T), the ground fault detection function is activated at the time the main power supply is turned on.	E014
Input overvoltage error	When Power supply overvoltage selection [bb-61] is Error (01), the inverter trips when persist overvoltage condition for more than 100 seconds while the inverter is in stop status. Input overvoltage level can be set by Power supply overvoltage level setting [bb-62].	E015
Temperature detector error	The inverter trips when there is a problem in the temperature detector circuit such as disconnection.	E019
Temperature error	Shuts off the inverter output and trips, when the internal temperature is above the threshold.	E021
CPU communication error	Shuts off the inverter output and trips, when occurs a communication error in an internal CPU.	E022
Input phase loss	Shuts off the inverter output and trips, when detects a phase loss of input side of main circuitry. Enable/disable of the input phase loss detection can be selected by Input phase loss detection enable [bb-65] setting. The single-phase inverters shut off the power when input phase loss. In this case, set [bb-65] to Disable (00).	E024
Main circuit error	Shuts off the inverter output and trips, when occurs a malfunction on the main circuit board.	E025
Analog input level over error	When [Ai1] input selection [Cb-08] or [Ai2] input selection [Cb-18] is Current (02), the inverter trips when excessive current come into the analog input terminal [Ai1]/[Ai2]. Power off the inverter when occurs this error, and check the wiring connection of analog input.	E026
Driver error	At the time of an instantaneous overcurrent from motor or external braking resistor, or the main element failure the inverter turns off the output to protect the main element.	E030
Output phase loss	Shuts off the inverter output and trips, when a loose connection, disconnection of output line, disconnection inside the motor, etc., are detected. Enable/disable of the output phase loss detection can be selected by Output phase loss detection enable [bb-66] setting. Detection of output phase loss is executed in the section of output frequency 5Hz to 100Hz.	E034
Thermistor error	Shuts off the inverter output and trips, when an abnormal temperature is observed with an external thermistor. When Thermistor type selection [Cb-40] is PTC (01), the input terminal [5] become for external PTC type thermistor. In this case, Input terminal [5] function [CA-05] setting is invalid. The threshold of abnormal temperature can be set by Thermistor error level [bb-70] and Thermistor gain adjustment [Cb-41]. When [Cb-40] is PTC (01), this error is occurred when the external thermistor is disconnected and re-generated after trip reset. In this case, it is required to connect the thermistor or short between [5] terminal and [L] terminal.	E035
Brake error	Shuts off the inverter output and trips, when the inverter can not detect whether the input function Answer back from brake [BOK] is ON or OFF during Brake release wait time ([AF131], [AF134]) after the inverter has output a Brake release [BRK]. When [BOK] is not assigned to Input terminal function [CA-01] to [CA-08]), this error is not occurred.	E036
Overload error at low speed	When the inverter operate lower than 0.2 Hz, shuts off the inverter output and trips when the electronic thermal function detects a motor overload monitoring the inverter output current to prevent the main element failure.	E038
Controller overload error	Shuts off the inverter output and trips when the thermal electronic function detects an inverter(controller) overload monitoring the inverter output current. When the controller overload error occurs, reset command can not be accepted for 10 seconds. There is no user parameter for controller (inverter) overload protection. The controller overload detection is according to the rated output current at ND rating. It is impossible to change the time until controller overload error and the behavior after controller overload error like Motor overload error [E005]. Regardless the setting of Load type selection [Ub-03], ND rated derating is applied. For detail, see Current Derating.	E039
Remote operator disconnection error	Shuts off the inverter output and trips, when occurs this error between optional remote operator and inverter due to noises, loose connection or disconnection. Enable/disable of the timeout detection between optional remote operator and inverter can be selected by Action selection at keypad disconnection [UA-20] setting.	E040
RS485 communication error	Shuts off the inverter output and trips, when RS485 communication timeout occurs because of a malfunction due to noises, loose wire connection, wiring disconnection, etc. Enable/disable of the RS485 communication timeout detection can be selected by RS485 communication error selection [CF-05] setting. This error may occur even if the communication settings with the connected control device do not match. In this case, the connection is not normally established and an error occurs in the host device. It is required to check the RS485 communication setting ([CF-01] to [CF-08]).	E041
RTC error	Shuts off the inverter output and trips, when the RTC data incorporated in the remote operator (VOP) has returned to the initial data.	E042
EzSQ inappropriate command error	Shuts off the inverter output and trips, when there is an inappropriate command in EzSQ program. This error is also occurred when the EzSQ program is executed despite it is not downloaded.	E043
EzSQ nesting error	Shuts off the inverter output and trips, when the nesting like subroutine, for, next, etc. exceeds 8 times in EzSQ program.	E044
EzSQ command execution error	Shuts off the inverter output and trips, when command cannot be processed appropriately while EzSQ program is executed such as overflow and 0-division.	E045
EzSQ user-assigned error 0 to 9	Shuts off the inverter output and trips, when the user-assigned trip command is executed in EzSQ program.	E050 to E059
Option error 0 to 9	Shuts off the inverter output and trips, when the inverter detects errors in the option mounted on the option I/F.	E060 to E069
STO shutoff error STO internal error STO path 1 error STO path 2 error	Shuts off the inverter output and trips, when the inverter detects errors in the circuit related to safety function STO.	E090 to E093
Encoder disconnection error	Shuts off the inverter output and trips, when the inverter detect an encoder wiring disconnection.	E100
Positioning range error	Shuts off the inverter output and trips, when he actual position exceeds the preset position range set by Position control range setting (forward) [AE-52] and Position control range setting (reverse) [AE-54].	E104
Speed deviation error	When Speed deviation error mode selection [bb-82] is Error (01), shuts off the inverter output and trips when the deviation between the frequency reference and the feedback speed exceeds the deviation specified in Speed deviation error detection level [bb-83]. When this error is occurred, output terminal function Speed over deviation [DSE] is turned on.	E105
Excessive speed error	Shuts off the inverter output and trips when the motor speed rises over a preset value set by Over-speed detection level [bb-80] for the time set by Over-speed detection time [bb-81].	E107
Contacting error	When output terminal function Contacting check signal [COK] is assigned to one of Input terminal function ([CA-01] to [CA-08]), shuts off the inverter output and trips when [COK] is not turned on/off for the time set by Contacting response check time [AF123] after operation of Contacting control [CON].	E110
PID soft start error	When PID soft start error detection enable [AH-81] is Enable(Error) (01), shuts off the inverter output and trips when a PID feedback value is not achieved a threshold level within the determined time. The time until trip can be set by PID soft start time [AH-80], and The threshold level of PID feedback value can be set by PID soft start error detection level [AH-82].	E120
Abnormal upper detecting error Abnormal lower detecting error	When Abnormal upper level detecting action [bE-05] and Abnormal lower level detecting action [bE-07] are Trip (02) or Trip after deceleration stop (03), shuts off the inverter output and trips when the value displayed on monitor function specified in Abnormal detection target [bE-02] exceeds or falls below the steady operation range. When the value exceeds the range, Abnormal upper detecting error [E121] is generated. When the value falls below the range, Abnormal lower detecting error [E122] is generated.	E121, E122

*1 When Electronic thermal decrease function enable [bC112] is Disable (00), the inverter does not accept a reset operation for 10 seconds. Wait for a while before performing a reset operation. When [bC112] is Enable (Linear decrement) (01) or Enable (Time constant decrement) (02), it can be reset immediately after error occurs. However, the overload accumulated value is not cleared and the value continue to decrease after reset operation. Therefore, when the inverter is restarted immediately after reset operation, the overload accumulated value may quickly reach 100% and the error may occur again. In this case, wait for a while before restarting.

Connecting Diagram

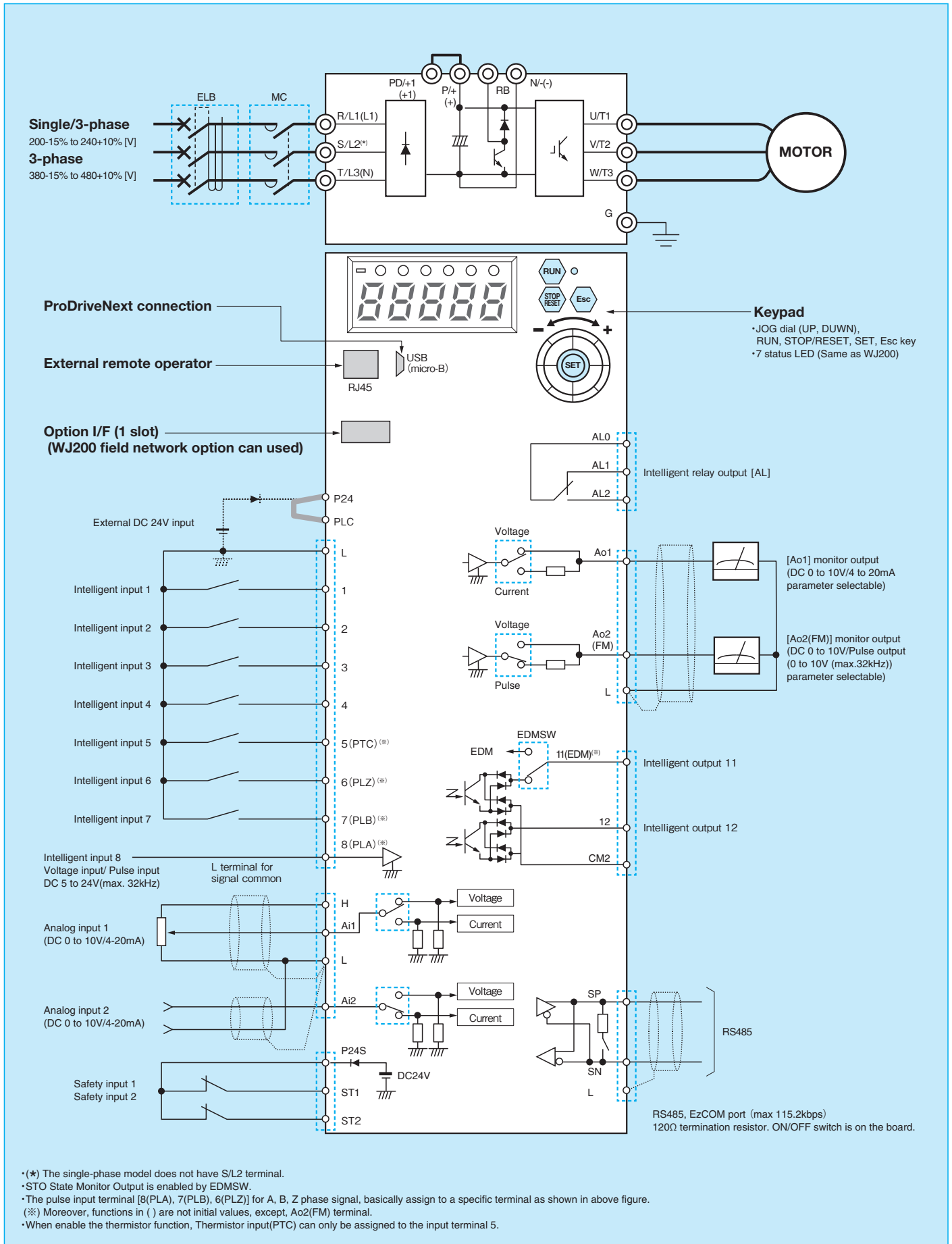

Connecting to PLC

Connecting the intelligent input terminals to a programmable controller

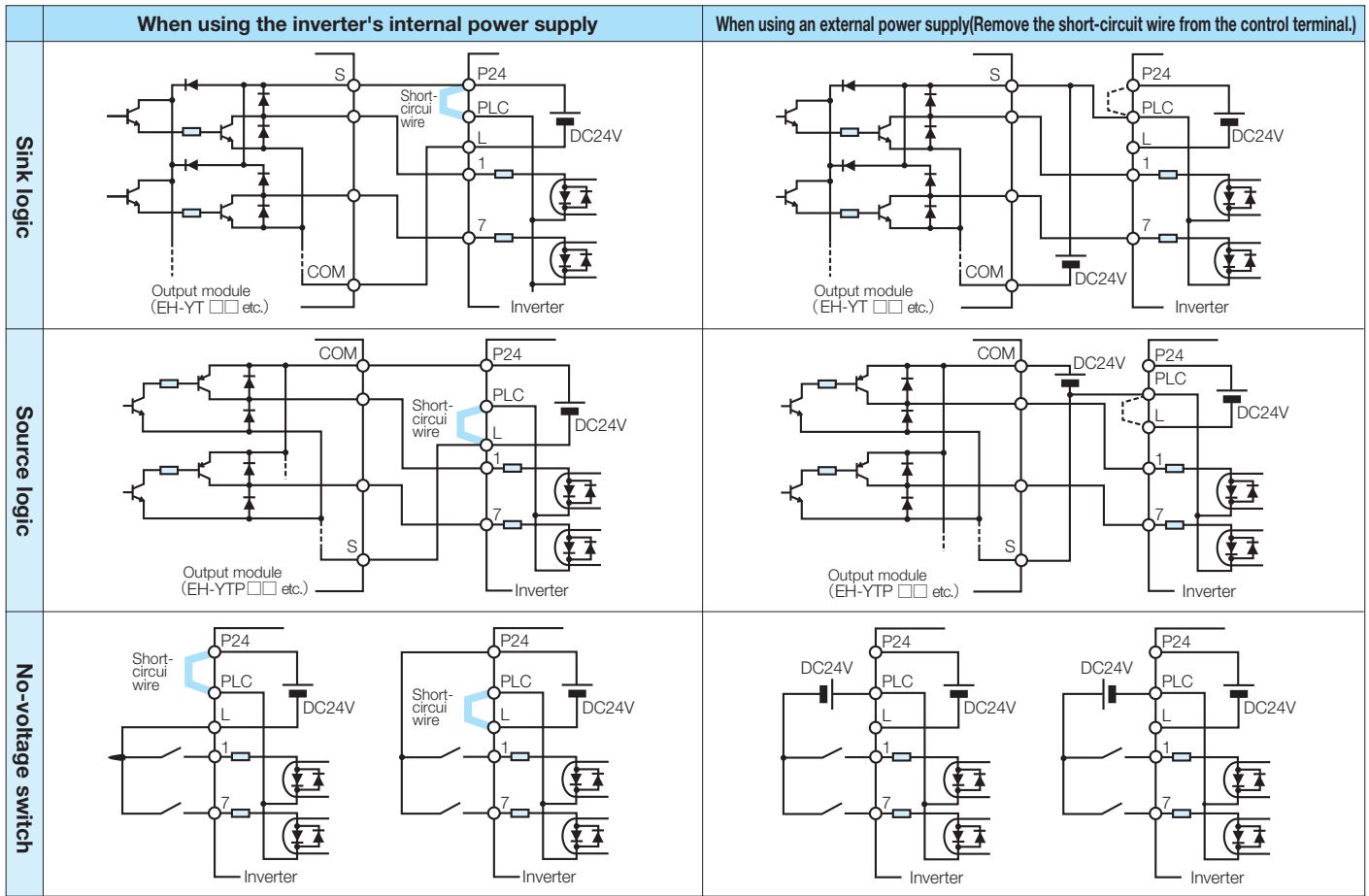

Connecting the intelligent output terminals to a programmable controller

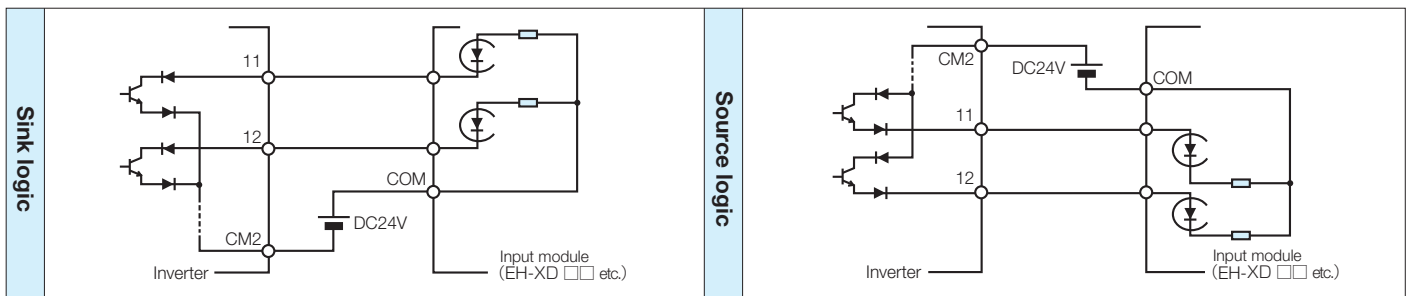

Cautions when using multiple inverters

If a common input (switch, etc.) is used for multiple inverters and the timing of power-on is different, the current may run around as shown in the figure on the right, and it may be recognized as ON even if the input is OFF. In that case, be sure to insert a diode (rated 50 V/0.1 A) in the positions shown in the figure to prevent the current flow round. For the source logic, refer to the User's Guide.

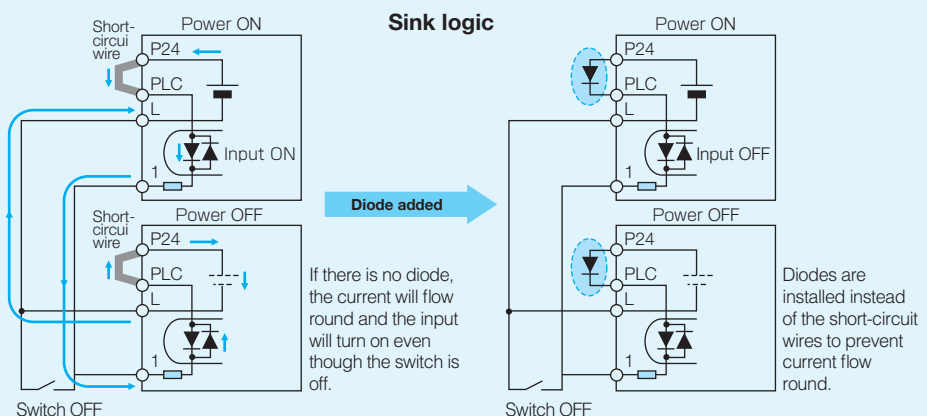

Wiring and Accessories

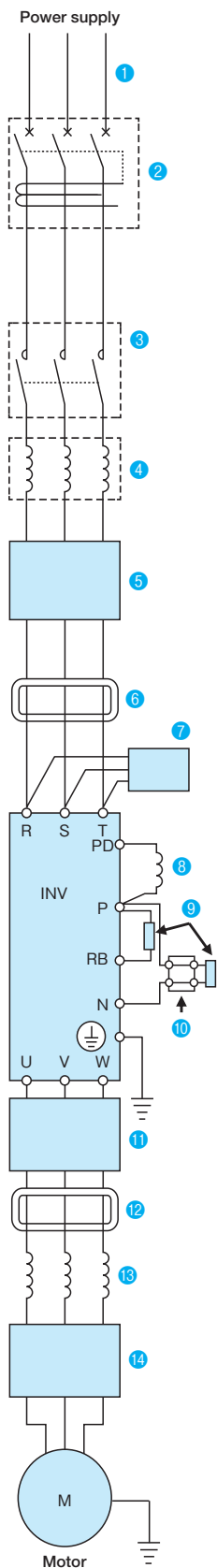

Voltage class	Applicable motor(kW) at ND rating	Model C1-*****2	Wiring					Applicable equipment								
			Main circuit terminal block wiring AWG (mm ²)	Terminal screw size (Terminal block width)	Crimp terminal Power/ Ground	Tightening torque N-m Power/Ground (maximum value)	Without reactor (DCL/ ALI)		With reactor (DCL or ALI)			Fuse				
							Earth-leakage breaker (ELB)	Magnetic contactor (MC)	Earth-leakage breaker (ELB)	Magnetic contactor (MC)	Time-delay	Semiconductor				
													Example Model	Rated current (A)	AC-1	AC-3
Single phase 200V	0.1	001SF	AWG16(1.3mm ²)	M3.5(7.3mm)	R2-35/R2-4	0.9-1.2/1.3-1.5(1.4/1.8)	EB-30E	5	HC8	HC8	EB-30E	5	HC8	HC8	3A	FWH-10A14F
	0.2	002SF	AWG16(1.3mm ²)	M3.5(7.3mm)	R2-35/R2-4	0.9-1.2/1.3-1.5(1.4/1.8)	EB-30E	5	HC8	HC8	EB-30E	5	HC8	HC8	6A	FWH-15A14F
	0.4	004SF	AWG16(1.3mm ²)	M3.5(7.3mm)	R2-35/R2-4	0.9-1.2/1.3-1.5(1.4/1.8)	EB-30E	10	HC8	HC8	EB-30E	5	HC8	HC8	10A	FWH-15A14F
	0.75	007SF	AWG12(3.3mm ²)	M4(9.9mm)	R5-5-4/R5-5-4	1.4/1.3-1.5(1.6/1.8)	EB-30E	15	HC8	HC10	EB-30E	10	HC8	HC8	20A	FWH-60B
	1.5	015SF	AWG10(5.3mm ²)	M4(9.9mm)	R5-5-4/R5-5-4	1.4/1.3-1.5(1.6/1.8)	EB-30E	20	HC8	HC20	EB-30E	10	HC8	HC8	30A	FWH-60B
Three phases 200V	0.1	001LF	AWG16(1.3mm ²)	M3.5(7.3mm)	R2-35/R2-4	0.9-1.2/1.3-1.5(1.4/1.8)	EB-30E	5	HC8	HC8	EB-30E	5	HC8	HC8	3A	FWH-10A14F
	0.2	002LF	AWG16(1.3mm ²)	M3.5(7.3mm)	R2-35/R2-4	0.9-1.2/1.3-1.5(1.4/1.8)	EB-30E	5	HC8	HC8	EB-30E	5	HC8	HC8	6A	FWH-15A14F
	0.4	004LF	AWG16(1.3mm ²)	M3.5(7.3mm)	R2-35/R2-4	0.9-1.2/1.3-1.5(1.4/1.8)	EB-30E	5	HC8	HC8	EB-30E	5	HC8	HC8	10A	FWH-15A14F
	0.75	007LF	AWG16(1.3mm ²)	M3.5(7.3mm)	R2-35/R2-4	0.9-1.2/1.3-1.5(1.4/1.8)	EB-30E	10	HC8	HC8	EB-30E	10	HC8	HC8	15A	FWH-25A14F
	1.5	015LF	AWG14(2.1mm ²)	M4(9.9mm)	R2-4/R2-4	1.4/1.3-1.5(1.6/1.8)	EB-30E	10	HC8	HC10	EB-30E	10	HC8	HC8	15A	FWH-25A14F
	2.2	022LF	AWG12(3.3mm ²)	M4(9.9mm)	R5-5-4/R5-5-4	1.4/1.3-1.5(1.6/1.8)	EB-30E	15	HC8	HC20	EB-30E	15	HC8	HC10	20A	FWH-60B
	3.7	037LF	AWG10(5.3mm ²)	M4(9.9mm)	R5-5-4/R5-5-4	1.4/1.3-1.5(1.6/1.8)	EB-30E	30	HC8	HC35	EB-30E	20	HC8	HC20	30A	FWH-60B
	5.5	055LF	AWG6(13mm ²)	M5(13mm)	R14-5/R14-5	3.0/3.0(3.0/3.0)	EB-50E	40	HC20	HC55	EB-50E	30	HC20	HC35	60A	FWH-150B
	7.5	075LF	AWG6(13mm ²)	M5(13mm)	R14-5/R14-5	3.0/3.0(3.0/3.0)	EB-50E	50	HC20	HC55	EB-50E	40	HC20	HC55	60A	FWH-150B
	11	110LF	AWG4(21mm ²)	M6(16.5mm)	R22-6/R22-6	3.9-5.0/3.9-5.0(5.2/5.2)	EB-100E	60	HC55	H65C	EB-50E	50	HC35	HC55	80A	FWH-200B
	15	150LF	AWG2(34mm ²)	M8(23mm)	R38-8/R38-8	5.9-8.8/5.9-8.8(10.5/10.5)	EB-100E	75	HC55	H80C	EB-100E	75	HC55	H65C	80A	FWH-200B
Three phases 400V	0.4	004HF	AWG16(1.3mm ²)	M4(9.9mm)	R2-4/R2-4	1.4/1.3-1.5(1.6/1.8)	EXK60-C	15	HC8	HC8	EXK60-C	15	HC8	HC8	6A	FWH-15A14F
	0.75	007HF	AWG16(1.3mm ²)	M4(9.9mm)	R2-4/R2-4	1.4/1.3-1.5(1.6/1.8)	EXK60-C	15	HC8	HC8	EXK60-C	15	HC8	HC8	10A	FWH-25A14F
	1.5	015HF	AWG16(1.3mm ²)	M4(9.9mm)	R2-4/R2-4	1.4/1.3-1.5(1.6/1.8)	EXK60-C	15	HC8	HC8	EXK60-C	15	HC8	HC8	10A	FWH-25A14F
	2.2	022HF	AWG14(2.1mm ²)	M4(9.9mm)	R2-4/R2-4	1.4/1.3-1.5(1.6/1.8)	EXK60-C	15	HC8	HC8	EXK60-C	15	HC8	HC8	10A	FWH-25A14F
	3.0	030HF	AWG14(2.1mm ²)	M4(9.9mm)	R2-4/R2-4	1.4/1.3-1.5(1.6/1.8)	EXK60-C	15	HC8	HC8	EXK60-C	15	HC8	HC8	15A	FWH-25A14F
	4.0	040HF	AWG12(3.3mm ²)	M4(9.9mm)	R5-5-4/R5-5-4	1.4/1.3-1.5(1.6/1.8)	EXK60-C	15	HC8	HC10	EXK60-C	15	HC8	HC8	15A	FWH-25A14F
	5.5	055HF	AWG10(5.3mm ²)	M5(13mm)	R5-5-4/R5-5-5	3.0/3.0(3.0/3.0)	EXK60-C	20	HC8	HC20	EXK60-C	15	HC8	HC20	30A	FWH-60B
	7.5	075HF	AWG10(5.3mm ²)	M5(13mm)	R5-5-4/R5-5-5	3.0/3.0(3.0/3.0)	EXK60-C	20	HC8	HC20	EXK60-C	20	HC8	HC20	30A	FWH-60B
	11	110HF	AWG6(13mm ²)	M6(16.5mm)	R14-6/R14-6	3.9-5.0/3.9-5.0(5.2/5.2)	EXK60-C	40	HC20	HC35	EXK60-C	30	HC20	HC35	50A	FWH-150B
	15	150HF	AWG6(13mm ²)	M6(16.5mm)	R14-6/R14-6	3.9-5.0/3.9-5.0(5.2/5.2)	EXK60-C	40	HC20	HC55	EXK60-C	40	HC20	HC50	50A	FWH-150B

Cautions

- The applicable devices shown in this chapter are those when Hitachi standard 3-phase 4-pole induction motor except 400 V class 3.0 kW and 4.0 kW is used.
- For the circuit breaker, choose an appropriate device by taking breaking capacity into consideration. (Use an inverter-compatible type.)
- To ensure safety, use an earth-leakage breaker (ELB).
- Use a 75°C copper wire (HIV wire).
- If the wiring length exceeds 20 m, a thick power line needs to be used.
- Use 0.75 mm² wire for relay output terminals.
- Tighten the terminal screws at specified torques. Loose tightening may cause a short circuit or fire. Excessive tightening may damage the terminal block or inverter.
- Employ different sensitive currents for earth-leakage breaker (ELB) depending on the total wiring length between the inverter and the power supply and between the inverter and the motor. Also, use an inverter-compatible type earth-leakage breaker. High-speed type products may malfunction.
- Leakage current is approx. 30 mA/km when XLPE wire is used and wired with a metal tube.
- As relative permittivity of HIV wire is high, the leakage current of HIV wire increases by about 8 times that of XLPE wire.
- Therefore, use an item with 8 times sensitivity current that is shown on the table right. If the total wiring length exceeds 100 m, use a XLPE wire.
- To comply with the UL standard, Class J time-delay fuses or semiconductor fuses of UL standard should be connected on the power supply side.









Total wiring length	Sensitivity current (mA)
100 m or shorter	30
300 m or shorter	100
800 m or shorter	200

No.	Name	Function
1	Wire	
2	Earth-leakage breaker (ELB)	Refer to table of the recommended wire diameter and wiring tools.
3	Magnetic contactor (MC)	
4	Input-side AC reactor (for harmonic suppression, power coordination, power factor improvement)	
5	Inverter noise filter	This is applied as a countermeasure against harmonic suppression, or when imbalance of power supply voltage is 3% or above, or when power supply capacity is 500 kVA or above. It is also used when a rapid change is made to power supply voltage. It is also effective in improving power factor.
6	Radio noise filter (Zero-phase reactor)	This reduces conducted noise generated from the inverter and transmitted through the wires. Connected to the primary side (input side) of the inverter.
7	Input-side radio noise filter	When the inverter is used, noise may be generated on an adjacent radio or other devices through wiring on the primary side (input side) of inverter. This is used for reducing the noise (reducing radiation noise).
8	DC link choke	This reduces the radiation noise that is emitted from the wire on the input side.
9	Braking resistor	This suppresses harmonics generated from the inverter.
10	Regenerative braking unit	This is used for increasing the braking torque of inverter, repeating power on and off at high interval, or reducing the speed of high load caused by moment of inertia.
11	Output-side noise filter	This is installed between the inverter and motor to reduce the radiation noise that is emitted from the wire. It is used to reduce radio interference on radios or televisions or prevent malfunctioning of measurement instruments and sensors.
12	Radio noise filter (Zero-phase reactor)	This is applied for reducing noise generated on the output side of inverter. (It can be used on both input side and output side.)
13	Output-side AC reactor for reducing vibration/preventing malfunctioning of thermal relay	When a general-use motor is driven by the inverter, compared with when it is run by commercial power supply, larger vibration may be generated. By connecting this device between the inverter and motor, the vibration of motor can be reduced. Also, if the wiring length between the inverter and motor is long (10 m or longer), by inserting a reactor, malfunctioning of the thermal relay caused by harmonic attributable to switching of inverter can be prevented. It is also possible to use a current sensor instead of a thermal relay.
14	LCR filter	This is an output-side sinusoidal filter to be installed between the inverter and motor to improve output current and voltage waveform to reduce motor vibration, noise, and radiation noise from wires. It is also effective in suppressing surge voltage.

Differences from WJ200

Item		WJ200	WJ-C1
Control method		V/f control Sensorless vector control PM sensorless vector control (synchronous start type)	V/f control IM sensorless vector control Sensorless vector control with encoder PM sensorless vector control (synchronous start type)
Keypad	Display	4-digit LED indication	5-digit LED indication
	Operation	Up/down button	JOG dial
Rated input voltage	200V	200 to 240V-15%/+10%	200 to 240V-15%/+10%
	400V	380 to 480V-15%/+10%	380 to 480V-15%/+10%
Mounting dimensions		Compatible with WJ200	
Max frequency	V/f	400Hz	590Hz
	Sensorless (IM)	400Hz	590Hz
	Sensorless (PM)	400Hz	590Hz
Control Circuit Terminals	Input terminal	7 terminals	8 terminals
	Frequency setting	2-terminal O (Voltage) / OI (Current)	2-terminal Ai1/Ai2 (Voltage/Current selectable)
	Monitor output	2-terminal AM (Voltage) / EO (Pulse)	2-terminal Ao1 (Voltage/Current selectable)/ Ao2 (Voltage/Pulse selectable)
USB connector		Mini-B	Micro-B
Functional safety		STO(Safe torque off) function EN 61800-5-2:2017, EN 61508(part 1-7):2010 EN ISO 13849-1:2015, EN ISO 13849-2:2012	STO(Safe torque off) function EN 61800-5-2:2017, EN 61508(part 1-7):2010 EN ISO 13849-1:2015, EN ISO 13849-2:2012
Communication function	Built-in terminal resistor	200Ω	120Ω
Record Number of Trip history		6 times	10 times
Simulation Mode		None	Available
Gain Mapping		None	Available
PID function		One system	Independent 2 systems, soft start function, sleep function
Multi-stage acceleration/deceleration		None	Available
Number of trip retries		3 times	5 times
Contactor control		None	Available
Life warning	Power modules	None	Available
	Inrush current limit circuit	None	Available
Emergency-force drive mode		None	Available
Tracing function		None	Available
Input/output phase loss error		None	Available
Overcurrent protection level		Fixed	Variable (parameter setting)
Speed command compensation with encoder		V/f control	V/f control IM sensorless vector control
Non-steady detection function		None	Available
Pulse input		Pulse-input A max. 32kHz Pulse-input B max. 2kHz	Pulse-input A max. 32kHz Pulse-input B max. 32kHz
Z phase input		None	Available
Parameter system		Basic mode	Basic mode/extended mode
External operator		OPE-SR mini OPE-SR, SBK WOP	OPE-SR mini (Basic mode) OPE-SR, SBK(Basic mode) WOP(Basic mode) VOP(Extended mode)

Communication Option

Name	Dimensions / Connecting																																											
WJ-ECT WJ-PB WJ-PN	<p data-bbox="428 251 1451 304">EtherCAT Communication Module (WJ-ECT) / PROFIBUS Communication Module (WJ-PB) / PROFINET Communication Module (WJ-PN)/CC-Link(WJ-CCL)</p> <p data-bbox="428 314 574 336">• Specifications</p> <table border="1" data-bbox="428 342 1508 1421"> <thead> <tr> <th data-bbox="428 342 565 363">Item</th> <th data-bbox="565 342 1508 363">Specification</th> </tr> </thead> <tbody> <tr> <td data-bbox="428 363 565 385" rowspan="10"> EtherCAT OPTION (WJ-ECT)  </td> <td data-bbox="565 363 1508 385">Communication protocol EtherCAT CiA402 Drive profile</td> </tr> <tr> <td data-bbox="565 385 1508 406">Physical layer 100BASE-TX (IEEE802.3)</td> </tr> <tr> <td data-bbox="565 406 1508 427">Connector RJ45 (IN / OUT)</td> </tr> <tr> <td data-bbox="565 427 1508 449">Communication distance Distance between nodes (between devices) : 100 [m] max</td> </tr> <tr> <td data-bbox="565 449 1508 470">Station address 1 to 99 : Set by the address setting switch, 1 to 65535 : Set by configuration (The station address setting depends on the addressing mode used by the EtherCAT master.)</td> </tr> <tr> <td data-bbox="565 470 1508 491">Distributed clock Free run mode (asynchronous)</td> </tr> <tr> <td data-bbox="565 491 1508 512">Process data PDO free mapping</td> </tr> <tr> <td data-bbox="565 512 1508 534">Mailbox (CoE) Emergency messages, SDO requests, SDO responses, Abort SDO</td> </tr> <tr> <td data-bbox="565 534 1508 555">CiA402 drive profile Velocity mode</td> </tr> <tr> <td data-bbox="565 555 1508 576">Recommended cable 100BX-TX support (category 5e or higher) STP (Shield twist pair) cable (Straight or Crossed)</td> </tr> <tr> <td data-bbox="428 576 565 661" rowspan="10"> PROFIBUS OPTION (WJ-PB)  </td> <td data-bbox="565 576 1508 597">Communication protocol PROFIBUS DPV0/PROFIBUS DPV1</td> </tr> <tr> <td data-bbox="565 597 1508 619">Connector, Cable D-sub 9 pin, PROFIBUS DP cable (EN 50170 part 8-2 as "Cable Type A")</td> </tr> <tr> <td data-bbox="565 619 1508 640">Node address 0 to 99 : set by rotary switches 0 to 126 : set by parameters</td> </tr> <tr> <td data-bbox="565 640 1508 661" rowspan="5"> Profile PROFIdrive </td> <td data-bbox="565 661 1508 683">Version 4.2</td> </tr> <tr> <td data-bbox="565 683 1508 704">Application class AC1 (Standard Drive)</td> </tr> <tr> <td data-bbox="565 704 1508 725">Telegram Standard telegram 1 WJ-PB telegram 103 (same as PPO3) / WJ-PB telegram 104 (same as PPO4) / WJ-PB telegram 105 (like PPO5)</td> </tr> <tr> <td data-bbox="565 725 1508 746">Telegram configuration From P160 to P179 parameters</td> </tr> <tr> <td data-bbox="565 746 1508 768">Operating mode Speed control mode</td> </tr> <tr> <td data-bbox="565 768 1508 789">Jogging Only jogging 1 is supported.</td> </tr> <tr> <td data-bbox="428 789 565 938" rowspan="10"> PROFINET OPTION (WJ-PN)  </td> <td data-bbox="565 789 1508 810">Communications protocol PROFINET IO Ver2.32</td> </tr> <tr> <td data-bbox="565 810 1508 832">Device type PROFINET IO Device</td> </tr> <tr> <td data-bbox="565 832 1508 853">Conformance class B</td> </tr> <tr> <td data-bbox="565 853 1508 874">Protocol DCP, LLDP, SNMP, MRP</td> </tr> <tr> <td data-bbox="565 874 1508 895">Netload I</td> </tr> <tr> <td data-bbox="565 895 1508 917">RT / IRT only RT</td> </tr> <tr> <td data-bbox="565 917 1508 938">Physical layer Auto negotiation (100BASE-TX (IEEE802.3) only)</td> </tr> <tr> <td data-bbox="565 938 1508 959">Connector RJ45 (Port1 / 2)</td> </tr> <tr> <td data-bbox="565 959 1508 981">MAC address 3 (Host, Port 1 / 2)</td> </tr> <tr> <td data-bbox="565 981 1508 1002">Recommended cable 100BASE-TX supported (category 5e or higher), STP cable (straight or cross allowed)</td> </tr> <tr> <td data-bbox="565 1002 1508 1023">Communications distance Distance between nodes: 100 [m] max</td> </tr> <tr> <td data-bbox="428 1023 565 1421" rowspan="7"> Profile PROFIdrive </td> <td data-bbox="565 1023 1508 1044">Version 4.2</td> </tr> <tr> <td data-bbox="565 1044 1508 1066">Application class AC1 (Standard Drive)</td> </tr> <tr> <td data-bbox="565 1066 1508 1087">Telegram Standard telegram 1 WJ-PN telegram 103 (same as PPO3 of PROFIdrive version 2) / WJ-PN telegram 104 (same as PPO4 of PROFIdrive version 2) / WJ-PN telegram 105 (like PPO5 of PROFIdrive version 2)</td> </tr> <tr> <td data-bbox="565 1087 1508 1108">Telegram configuration From P160 to P179 parameters</td> </tr> <tr> <td data-bbox="565 1108 1508 1129">Operating mode Speed control mode</td> </tr> <tr> <td data-bbox="565 1129 1508 1151">Jogging Only jogging 1 is supported.</td> </tr> </tbody> </table> <p data-bbox="428 1464 558 1485">Dimensions</p> <p data-bbox="483 1513 646 1534">• EtherCAT WJ-ECT</p> <p data-bbox="824 1513 987 1534">• PROFIBUS WJ-PB</p> <p data-bbox="1166 1513 1328 1534">• PROFINET WJ-PN</p> <div data-bbox="483 1561 760 1789"> </div> <div data-bbox="824 1561 1101 1789"> </div> <div data-bbox="1166 1561 1442 1789"> </div> <div data-bbox="483 1825 695 2008"> </div> <div data-bbox="824 1825 1036 2008"> </div> <div data-bbox="1166 1825 1377 2008"> </div>	Item	Specification	EtherCAT OPTION (WJ-ECT) 	Communication protocol EtherCAT CiA402 Drive profile	Physical layer 100BASE-TX (IEEE802.3)	Connector RJ45 (IN / OUT)	Communication distance Distance between nodes (between devices) : 100 [m] max	Station address 1 to 99 : Set by the address setting switch, 1 to 65535 : Set by configuration (The station address setting depends on the addressing mode used by the EtherCAT master.)	Distributed clock Free run mode (asynchronous)	Process data PDO free mapping	Mailbox (CoE) Emergency messages, SDO requests, SDO responses, Abort SDO	CiA402 drive profile Velocity mode	Recommended cable 100BX-TX support (category 5e or higher) STP (Shield twist pair) cable (Straight or Crossed)	PROFIBUS OPTION (WJ-PB) 	Communication protocol PROFIBUS DPV0/PROFIBUS DPV1	Connector, Cable D-sub 9 pin, PROFIBUS DP cable (EN 50170 part 8-2 as "Cable Type A")	Node address 0 to 99 : set by rotary switches 0 to 126 : set by parameters	Profile PROFIdrive	Version 4.2	Application class AC1 (Standard Drive)	Telegram Standard telegram 1 WJ-PB telegram 103 (same as PPO3) / WJ-PB telegram 104 (same as PPO4) / WJ-PB telegram 105 (like PPO5)	Telegram configuration From P160 to P179 parameters	Operating mode Speed control mode	Jogging Only jogging 1 is supported.	PROFINET OPTION (WJ-PN) 	Communications protocol PROFINET IO Ver2.32	Device type PROFINET IO Device	Conformance class B	Protocol DCP, LLDP, SNMP, MRP	Netload I	RT / IRT only RT	Physical layer Auto negotiation (100BASE-TX (IEEE802.3) only)	Connector RJ45 (Port1 / 2)	MAC address 3 (Host, Port 1 / 2)	Recommended cable 100BASE-TX supported (category 5e or higher), STP cable (straight or cross allowed)	Communications distance Distance between nodes: 100 [m] max	Profile PROFIdrive	Version 4.2	Application class AC1 (Standard Drive)	Telegram Standard telegram 1 WJ-PN telegram 103 (same as PPO3 of PROFIdrive version 2) / WJ-PN telegram 104 (same as PPO4 of PROFIdrive version 2) / WJ-PN telegram 105 (like PPO5 of PROFIdrive version 2)	Telegram configuration From P160 to P179 parameters	Operating mode Speed control mode	Jogging Only jogging 1 is supported.
Item	Specification																																											
EtherCAT OPTION (WJ-ECT) 	Communication protocol EtherCAT CiA402 Drive profile																																											
	Physical layer 100BASE-TX (IEEE802.3)																																											
	Connector RJ45 (IN / OUT)																																											
	Communication distance Distance between nodes (between devices) : 100 [m] max																																											
	Station address 1 to 99 : Set by the address setting switch, 1 to 65535 : Set by configuration (The station address setting depends on the addressing mode used by the EtherCAT master.)																																											
	Distributed clock Free run mode (asynchronous)																																											
	Process data PDO free mapping																																											
	Mailbox (CoE) Emergency messages, SDO requests, SDO responses, Abort SDO																																											
	CiA402 drive profile Velocity mode																																											
	Recommended cable 100BX-TX support (category 5e or higher) STP (Shield twist pair) cable (Straight or Crossed)																																											
PROFIBUS OPTION (WJ-PB) 	Communication protocol PROFIBUS DPV0/PROFIBUS DPV1																																											
	Connector, Cable D-sub 9 pin, PROFIBUS DP cable (EN 50170 part 8-2 as "Cable Type A")																																											
	Node address 0 to 99 : set by rotary switches 0 to 126 : set by parameters																																											
	Profile PROFIdrive	Version 4.2																																										
		Application class AC1 (Standard Drive)																																										
		Telegram Standard telegram 1 WJ-PB telegram 103 (same as PPO3) / WJ-PB telegram 104 (same as PPO4) / WJ-PB telegram 105 (like PPO5)																																										
		Telegram configuration From P160 to P179 parameters																																										
		Operating mode Speed control mode																																										
	Jogging Only jogging 1 is supported.																																											
	PROFINET OPTION (WJ-PN) 	Communications protocol PROFINET IO Ver2.32																																										
Device type PROFINET IO Device																																												
Conformance class B																																												
Protocol DCP, LLDP, SNMP, MRP																																												
Netload I																																												
RT / IRT only RT																																												
Physical layer Auto negotiation (100BASE-TX (IEEE802.3) only)																																												
Connector RJ45 (Port1 / 2)																																												
MAC address 3 (Host, Port 1 / 2)																																												
Recommended cable 100BASE-TX supported (category 5e or higher), STP cable (straight or cross allowed)																																												
Communications distance Distance between nodes: 100 [m] max																																												
Profile PROFIdrive	Version 4.2																																											
	Application class AC1 (Standard Drive)																																											
	Telegram Standard telegram 1 WJ-PN telegram 103 (same as PPO3 of PROFIdrive version 2) / WJ-PN telegram 104 (same as PPO4 of PROFIdrive version 2) / WJ-PN telegram 105 (like PPO5 of PROFIdrive version 2)																																											
	Telegram configuration From P160 to P179 parameters																																											
	Operating mode Speed control mode																																											
	Jogging Only jogging 1 is supported.																																											

Communication Option

Name	Dimensions / Connecting																																												
WJ-CCL	<table border="1"> <thead> <tr> <th>Item</th> <th>Specification</th> </tr> </thead> <tbody> <tr> <td>Shape</td> <td>Option unit (can be mounted later), connector connection</td> </tr> <tr> <td>Power supply</td> <td>DC3V and DC5V are supplied from inverter. Power is supplied from the external 24V input connector and parameters of WJ-CCL and inverter can be set. However, the inverter cannot be operated.</td> </tr> <tr> <td>Wire size</td> <td>0.14 to 1.5mm² (28 to 16AWG) applies to external 24V input connector.</td> </tr> <tr> <td>Ambient temperature</td> <td>0 to 50°C Other general specifications is accordance with inverter.</td> </tr> <tr> <td>24V control power supply current</td> <td>320mA (Consider separately when using an external device via the inverter-controlled terminal.)</td> </tr> <tr> <td>Station type</td> <td>Remote device station</td> </tr> <tr> <td>Communication speed</td> <td>10M/5M/2.5M/625k/156kbps (Communication speed is selectable by DIP switch.)</td> </tr> <tr> <td>Station number</td> <td>1 to 64 (Station number is selectable by the rotary switch.)</td> </tr> <tr> <td>CC-Link Ver.</td> <td>1(1.00 and 1.10), 2 (CC-Link Version is selectable by DIP switch.)</td> </tr> <tr> <td>Extended cyclic setting</td> <td>Single, double, quadruple, and octuple (Setting is selectable by DIP switch.)</td> </tr> <tr> <td>Communication method</td> <td>Broadcast polling method</td> </tr> <tr> <td>Synchronization method</td> <td>Frame synchronization method</td> </tr> <tr> <td>Encoding method</td> <td>NRZI</td> </tr> <tr> <td>Transmission path format</td> <td>Path format (EIA RS485 compliant)</td> </tr> <tr> <td>Transmission format</td> <td>HDLC compliant</td> </tr> <tr> <td>Error control system</td> <td>CRC(X¹⁶ + X¹² + X⁶ + 1)</td> </tr> <tr> <td>Number of Occupied station</td> <td>1 station fixed</td> </tr> <tr> <td>Number of link points</td> <td>RX, RY:32 points Single :RWw: 4 points / RWr: 4 points Double: RWw: 8 points/RWr: 8 points Quadruple: RWw:16 point/RWr:16 point Octuple: RWw:32 point/RWr:32 point</td> </tr> <tr> <td>Number of connected units</td> <td>Up to 64 units (Number of connected units is depending on the device to be connected. Up to 42 units when only WJ-C1 is connected.)</td> </tr> <tr> <td>Connection cable</td> <td>CC-Link dedicated cable Ver.1.10, CC-Link dedicated high flexible cable for Ver.1.10, CC-Link dedicated cable</td> </tr> <tr> <td>Terminal resistance</td> <td>110 Ω (normally use) or 130 Ω can be selected by the terminal resistance switch (DIP switch).</td> </tr> </tbody> </table>	Item	Specification	Shape	Option unit (can be mounted later), connector connection	Power supply	DC3V and DC5V are supplied from inverter. Power is supplied from the external 24V input connector and parameters of WJ-CCL and inverter can be set. However, the inverter cannot be operated.	Wire size	0.14 to 1.5mm ² (28 to 16AWG) applies to external 24V input connector.	Ambient temperature	0 to 50°C Other general specifications is accordance with inverter.	24V control power supply current	320mA (Consider separately when using an external device via the inverter-controlled terminal.)	Station type	Remote device station	Communication speed	10M/5M/2.5M/625k/156kbps (Communication speed is selectable by DIP switch.)	Station number	1 to 64 (Station number is selectable by the rotary switch.)	CC-Link Ver.	1(1.00 and 1.10), 2 (CC-Link Version is selectable by DIP switch.)	Extended cyclic setting	Single, double, quadruple, and octuple (Setting is selectable by DIP switch.)	Communication method	Broadcast polling method	Synchronization method	Frame synchronization method	Encoding method	NRZI	Transmission path format	Path format (EIA RS485 compliant)	Transmission format	HDLC compliant	Error control system	CRC(X ¹⁶ + X ¹² + X ⁶ + 1)	Number of Occupied station	1 station fixed	Number of link points	RX, RY:32 points Single :RWw: 4 points / RWr: 4 points Double: RWw: 8 points/RWr: 8 points Quadruple: RWw:16 point/RWr:16 point Octuple: RWw:32 point/RWr:32 point	Number of connected units	Up to 64 units (Number of connected units is depending on the device to be connected. Up to 42 units when only WJ-C1 is connected.)	Connection cable	CC-Link dedicated cable Ver.1.10, CC-Link dedicated high flexible cable for Ver.1.10, CC-Link dedicated cable	Terminal resistance	110 Ω (normally use) or 130 Ω can be selected by the terminal resistance switch (DIP switch).
	Item	Specification																																											
	Shape	Option unit (can be mounted later), connector connection																																											
	Power supply	DC3V and DC5V are supplied from inverter. Power is supplied from the external 24V input connector and parameters of WJ-CCL and inverter can be set. However, the inverter cannot be operated.																																											
	Wire size	0.14 to 1.5mm ² (28 to 16AWG) applies to external 24V input connector.																																											
	Ambient temperature	0 to 50°C Other general specifications is accordance with inverter.																																											
	24V control power supply current	320mA (Consider separately when using an external device via the inverter-controlled terminal.)																																											
	Station type	Remote device station																																											
	Communication speed	10M/5M/2.5M/625k/156kbps (Communication speed is selectable by DIP switch.)																																											
	Station number	1 to 64 (Station number is selectable by the rotary switch.)																																											
	CC-Link Ver.	1(1.00 and 1.10), 2 (CC-Link Version is selectable by DIP switch.)																																											
	Extended cyclic setting	Single, double, quadruple, and octuple (Setting is selectable by DIP switch.)																																											
	Communication method	Broadcast polling method																																											
	Synchronization method	Frame synchronization method																																											
	Encoding method	NRZI																																											
	Transmission path format	Path format (EIA RS485 compliant)																																											
	Transmission format	HDLC compliant																																											
	Error control system	CRC(X ¹⁶ + X ¹² + X ⁶ + 1)																																											
Number of Occupied station	1 station fixed																																												
Number of link points	RX, RY:32 points Single :RWw: 4 points / RWr: 4 points Double: RWw: 8 points/RWr: 8 points Quadruple: RWw:16 point/RWr:16 point Octuple: RWw:32 point/RWr:32 point																																												
Number of connected units	Up to 64 units (Number of connected units is depending on the device to be connected. Up to 42 units when only WJ-C1 is connected.)																																												
Connection cable	CC-Link dedicated cable Ver.1.10, CC-Link dedicated high flexible cable for Ver.1.10, CC-Link dedicated cable																																												
Terminal resistance	110 Ω (normally use) or 130 Ω can be selected by the terminal resistance switch (DIP switch).																																												

Connector	Manufacturer	Model	Number of accessories
CC-Link connector	3M Japan Limited	35505-6000-BOMGF	2 pieces
External 24V input connector	Phoenix Contact GmbH & Co. KG.	MC 1.5/2-ST-3.5	1 piece

Connector	Symbol	Signal Type	Covering Color
CC-Link connector	DA	Communication data High	Blue
	DB	Communication data Low	White
	DG	Signal ground	Yellow
	(NC)	—	—
	SLD	Shield	(Shield)
External 24V input connector	24V	External 24VDC power	—
	L	External power supply common	—

Dimensions

• WJ-CCL

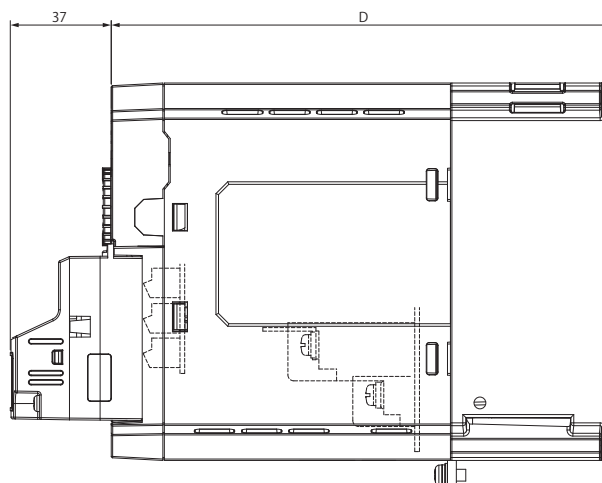
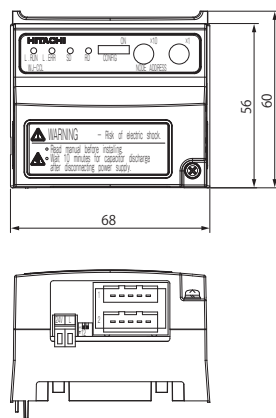

When mounting the communication option on WJ-C1, the D (depth) dimension is increased by 37mm. Take care when the communication option on WJ-C1 is installed in the cabinet.

Current Derating

Derating necessity table

Single-phase 200 V	Required	Three-phase 200 V	Required	Three-phase 400 V	Required
C1-001SF2	-	C1-001LF2	-	C1-004HF2	√
C1-002SF2	-	C1-002LF2	√	C1-007HF2	√
C1-004SF2	√	C1-004LF2	-	C1-015HF2	-
C1-007SF2	√	C1-007LF2	-	C1-022HF2	-
C1-015SF2	-	C1-015LF2	-	C1-030HF2	-
C1-022SF2	-	C1-022LF2	-	C1-040HF2	√
-	-	C1-037LF2	√	C1-055HF2	-
-	-	C1-055LF2	-	C1-075HF2	-
-	-	C1-075LF2	-	C1-110HF2	-
-	-	C1-110LF2	√	C1-150HF2	√
-	-	C1-150LF2	√	-	-

√ : Derating required - : Derating not required

Models requiring no current derating

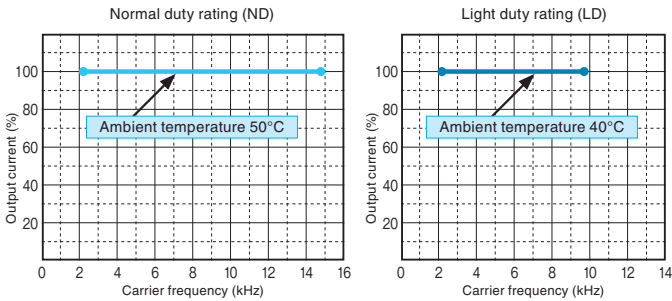

Models requiring current derating

C1-002LF2

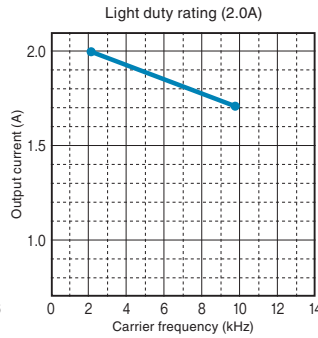
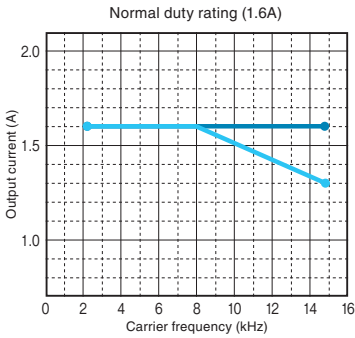

C1-004SF2

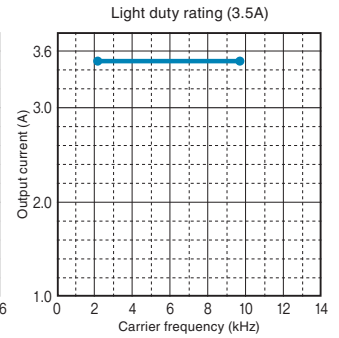
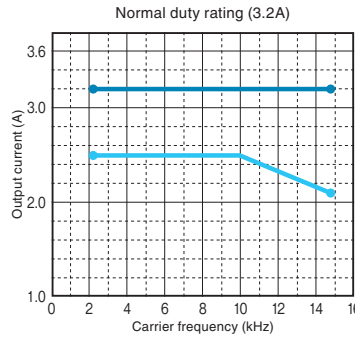

C1-004HF2

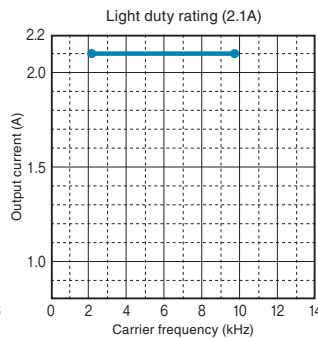
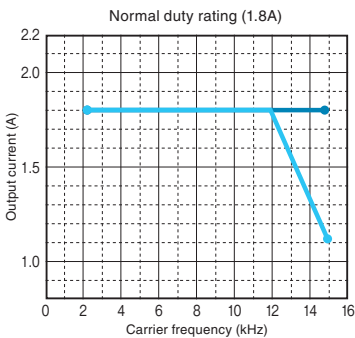

C1-037LF2

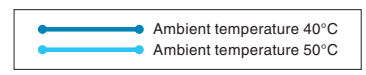
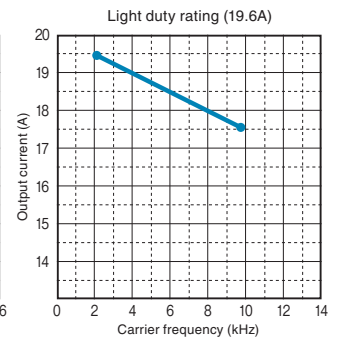
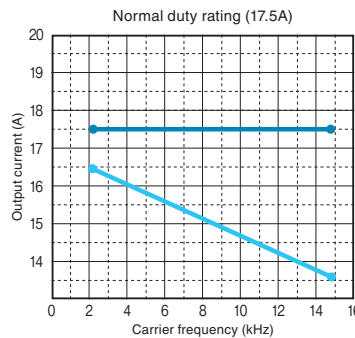

Current Derating

Models requiring current derating

• C1-007SF2

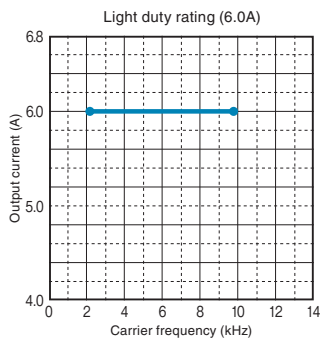
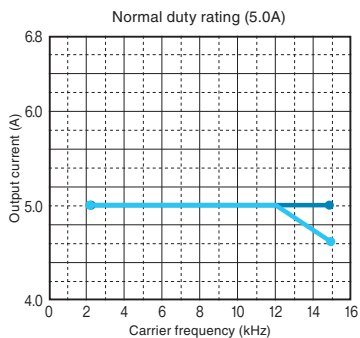

• C1-007HF2

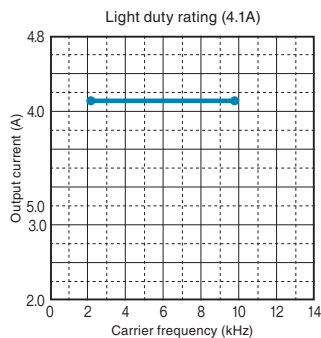
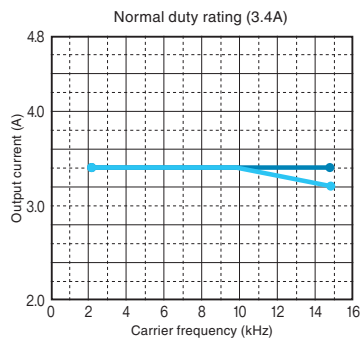

• C1-040HF2

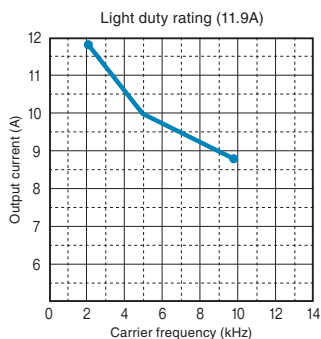
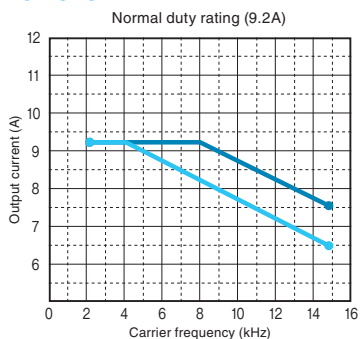

• C1-110LF2

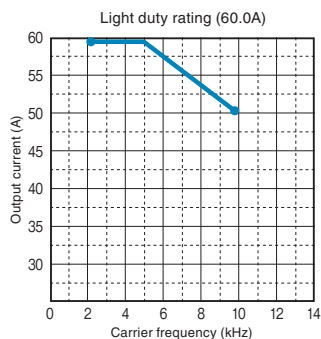
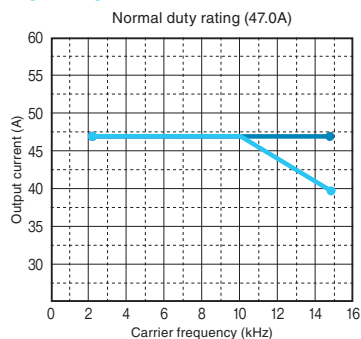

• C1-150LF2

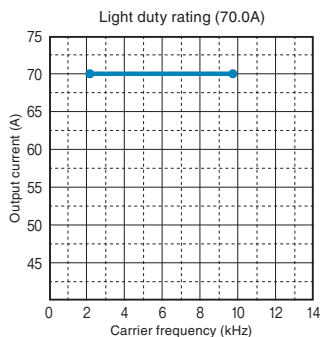
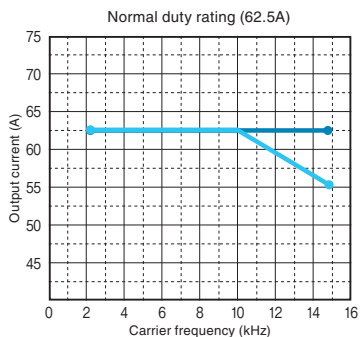

• C1-150HF2

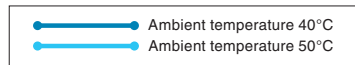
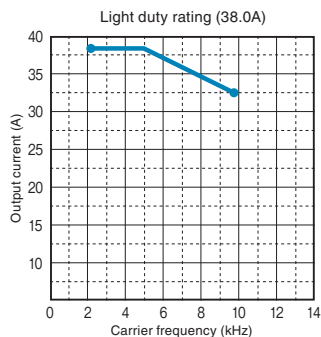
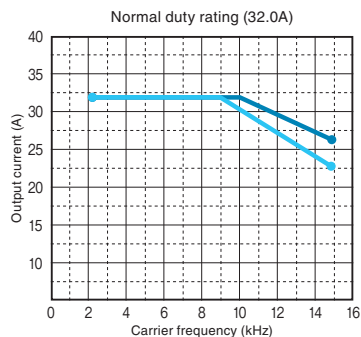

For Correct Operation

Application to Motors

Application to general-purpose motors

Operating frequency	For operation at higher than 60Hz, it is required to examine the allowable torque of the motor, useful life of bearings, noise, vibration, etc. In this case, be sure to consult the motor manufacturer as the maximum allowable rpm differs depending on the motor capacity, etc.
Torque characteristics	The torque characteristics of driving a general-purpose motor with an inverter differ from those of driving it using commercial power (starting torque decreases in particular). Carefully check the load torque characteristic of a connected machine and the driving torque characteristic of the motor.
Motor loss and temperature increase	An inverter-driven general-purpose motor heats up quickly at lower speeds. Consequently, the continuous torque level (output) will decrease at lower motor speeds. Carefully check the torque characteristics vs speed range requirements.
Noise	A general-purpose motor audible noise run by an inverter is slightly greater than it by a commercial power.
Vibration	When run by an inverter at variable speeds, the motor may generate vibration, especially because of (a) unbalance of the rotor including a connected machine, or (b) resonance caused by the natural vibration frequency of a mechanical system. Particularly, be careful of (b) when operating at variable speeds a machine previously fitted with a constant speed motor. Vibration can be minimized by (1) avoiding resonance points using the frequency jump function of the inverter, (2) using a tireshaped coupling, or (3) placing a rubber shock absorber beneath the motor base.
Power transmission mechanism	Under continued, low-speed operation, oil lubrication can deteriorate in a power transmission mechanism with an oil-type gear box (gear motor) or reducer. Check with the motor manufacturer for the permissible range of continuous speed. To operate at more than 60Hz, confirm the machine's ability to withstand the centrifugal force generated.

Application to special motors

Gear motor	The allowable rotation range of continuous drive varies depending on the lubrication method or motor manufacturer. (Particularly in case of oil lubrication, pay attention to the low frequency range.)
Brake-equipped motor	For use of a brake-equipped motor, be sure to connect the braking power supply from the primary side of the inverter.
Pole-change motor	There are different kinds of pole-change motors (constant output characteristic type, constant torque characteristic type, etc.), with different rated current values. In motor selection, check the maximum allowable current for each motor of a different pole count. At the time of pole changing, be sure to stop the motor. Also see: Application to the 400V-class motor.
Submersible motor	The rated current of a submersible motor is significantly larger than that of the general-purpose motor. In inverter selection, be sure to check the rated current of the motor.
Explosion-proof motor	Inverter drive is not suitable for a safety-enhanced explosion-proof type motor. The inverter should be used in combination with a pressure-proof explosion-proof type of motor.
Synchronous (MS) motor High-speed (HFM) motor	In most cases, the synchronous (MS) motor and the high-speed (HFM) motor are designed and manufactured to meet the specifications suitable for a connected machine. As to proper inverter selection, consult the manufacturer.
Single-phase motor	A single-phase motor is not suitable for variable-speed operation by an inverter drive. Therefore, use a three-phase motor.
Permanent magnet motor	Voltage is induced at the motor power terminal during motor rotation even if the inverter power supply is cut off. Therefore, please do not touch the terminals of the motor and inverter during motor rotation. PM motor can not be operated with commercial power supply. In addition, PM motor and inverter are ""one to one"" combination. Contact your dealer when you use PM motor.

Application to the 400V-class motor

A system applying a voltage-type PWM inverter with IGBT may have surge voltage at the motor terminals resulting from the cable constants including the cable length and the cable laying method. Depending on the surge current magnification, the motor coil insulation may be degraded. In particular, when a 400V-class motor is used, a longer cable is used, and critical loss can occur, take any of the following countermeasures:

- (1) install the LCR filter between the inverter and the motor,
- (2) install the AC reactor between the inverter and the motor, or (3) enhance the insulation of the motor coil.

Notes on Use

Drive

Run/Stop	Run or stop of the inverter must be done with the keys on the operator or through the control circuit terminal. Do not operate by installing a electromagnetic contactor (MC) in the main circuit.
Emergency motor stop	When the protective function is operating or the power supply stops, the motor enters the free run stop state. When an emergency stop is required or when the motor should be kept stopped, use of a mechanical brake should be considered.
High-frequency run	A max. 590Hz can be selected on the WJ series C1. However, a two-pole motor can attain up to approx. 35,400 min ⁻¹ , which is extremely dangerous. Therefore, carefully make selection and settings by checking the mechanical strength of the motor and connected machines. Consult the motor manufacturer when it is necessary to drive a standard (general-purpose) motor above 60Hz. High frequency motors are also available in Hitachi.

Repetitive operation on starting or plugging

About frequent repetition use (crane, elevator, press, washing machine), a power semiconductor (IGBT, a rectification diode, thyristor) in the inverter may come to remarkably have a short life by thermal fatigue. The life can be prolonged by lower a load electric current, lengthen acceleration / deceleration time, lower carrier frequency, or increasing capacity of the inverter.

Operation use in highlands beyond 1,000m above sea level

Due to the air density decreasing, whenever standard inverters are used for altitudes above 1000m, the following conditions are additionally required for proper operation. In application for operation over 2500m, kindly contact your nearest sales office for assistance.

1. Reduction of inverter rated current
Current rating has to be reduced 1% for every 100m that exceeds from an altitude of 1000m.
For example, for inverters placed at an altitude of 2000m, the rated current has to be reduced 10% (Rated current x0.9) from its original amount.
{(2000m-1000m)/100m x 1% = 10%}
2. Reduction of breakdown voltage
Whenever an inverter is used at altitudes beyond 1000m, the breakdown voltage decreases as follows:
1000m or less: 1.00 / 1500m: 0.95 / 2000m: 0.90 / 2500m: 0.85. As mentioned in the user's guide, please avoid any withstand voltage test.

Installation location and operating environment

Avoid installation in areas of high temperature, excessive humidity, or where moisture can easily collect, as well as areas that are dusty, subject to corrosive gasses, mist of liquid for grinding, or salt. Install the inverter away from direct sunlight in a well-ventilated room that is free of vibration. The inverter can be operated in the ambient temperature range from WJ series C1(ND):-10°C to 50°C, WJ series C1(LD):-10°C to 40°C. When the ambient temperature ranges 40 and 50°C, the carrier frequency and the output current must be limited depending on the load type. Please refer to the user's guide.

Main power supply

<p>Installation of an AC reactor on the input side</p>	<p>In the following examples involving a general-purpose inverter, a large peak current flows on the main power supply side, and is able to destroy the converter module. Where such situations are foreseen or the connected equipment must be highly reliable, install an AC reactor between the power supply and the inverter. Also, where influence of indirect lightning strike is possible, install a lightning conductor.</p> <p>(A) The unbalance factor of the power supply is 3% or higher. (Note) (B) The power supply capacity is at least 10 times greater than the inverter capacity (the power supply capacity is 500 kVA or more). (C) Abrupt power supply changes are expected.</p> <p>Examples: (1) Several inverters are interconnected with a short bus. (2) A thyristor converter and an inverter are interconnected with a short bus. (3) An installed phase advance capacitor opens and closes.</p> <p>In cases (A), (B) and (C), it is recommended to install an AC reactor on the main power supply side. Note: Example calculation with $V_{RS} = 205V$, $V_{ST} = 201V$, $V_{TR} = 200V$ V_{RS}: R-S line voltage, V_{ST}: S-T line voltage, V_{TR}: T-R line voltage</p> $\text{Unbalance factor of voltage} = \frac{\text{Max. line voltage (min.)} - \text{Mean line voltage}}{\text{Mean line voltage}} \times 100$ $= \frac{V_{RS} - (V_{RS} + V_{ST} + V_{TR})/3}{(V_{RS} + V_{ST} + V_{TR})/3} \times 100 = \frac{205 - 202}{202} \times 100 = 1.5(\%)$
<p>Using a private power generator</p>	<p>An inverter run by a private power generator may overheat the generator or suffer from a deformed output voltage waveform of the generator. Generally, the generator capacity should be five times that of the inverter (kVA) in a PWM control system, or six times greater in a PAM control system.</p>

Notes on Peripheral Equipment Selection

<p>Wiring connections</p>	<p>(1) Be sure to connect main power wires with R/L1 (Single-phase: L1), S/L2, T/L3 (Single-phase: N) terminals (input) and motor wires to U (T1), V (T2), and W (T3) terminals (output). (Incorrect connection will cause an immediate failure.) (2) Be sure to provide a grounding connection with the ground terminal (⊕).</p>
<p>Wiring between inverter and motor</p>	<p>Electromagnetic contactor When an electromagnetic contactor is installed between the inverter and the motor, do not perform on-off switching during running operation.</p> <p>Thermal relay When an inverter is used with a standard applicable output motor (Hitachi standard three-phase squirrel-cage four-pole motor), a thermal relay for motor protection is not required due to the internal electronic protective function. A thermal relay, however, should be used: • during continuous running outside a range of 30 to 60 Hz. • for motors exceeding the range of electronic thermal adjustment (rated current). • when several motors are driven by the same inverter; install a thermal relay for each motor. • The RC value of the thermal relay should be more than 1.1 times the rated current of the motor. If the wiring length is 10 m or more, the thermal relay tends to turn off readily. In this case, provide an AC reactor on the output side or use a current sensor.</p>
<p>Installing a circuit breaker</p>	<p>Install a circuit breaker on the main power input side to protect inverter wiring and ensure personal safety. Choose an inverter-compatible circuit breaker. The conventional type may malfunction due to harmonics from the inverter. For more information, consult the circuit breaker manufacturer.</p>
<p>Wiring distance</p>	<p>The wiring distance between the inverter and the remote operator should be 20 meters or less. Shielded cable should be used on the wiring. Beware of voltage drops on main circuit wires. (A large voltage drop reduces torque.)</p>
<p>Earth leakage relay</p>	<p>If the earth leakage relay (or earth leakage breaker) is used, it should have a sensitivity level of 30 mA or more (per inverter).</p>
<p>Phase advance capacitor</p>	<p>Do not use a capacitor for power factor improvement between the inverter and the motor because the high-frequency components of the inverter output may overheat or damage the capacitor.</p>

High-frequency Noise and Leakage Current

- (1) High-frequency components are included in the input/output of the inverter main circuit, and they may cause interference in a transmitter, radio, or sensor if used near the inverter. The interference can be minimized by attaching noise filters (option) in the inverter circuitry.
- (2) The switching action of an inverter causes an increase in leakage current. Be sure to ground the inverter and the motor.

Lifetime of Primary Parts

Because a DC bus capacitor deteriorates as it undergoes internal chemical reaction, it should normally be replaced every 10 years. Be aware, however, that its life expectancy is considerably shorter when the inverter is subjected to such adverse factors as high temperatures or heavy loads exceeding the rated current of the inverter. The approximate lifetime of the capacitor is as shown in the figure at the right when it is used 24 hours daily (80% ND load). JEMA standard is the 5 years at ambient temperature 40°C used in 12 hours daily. (According to the "Instructions for Periodic Inspection of General-Purpose Inverter" (JEMA).) Also, such moving parts as a cooling fan should be replaced. Maintenance inspection and parts replacement must be performed by only specified trained personnel. Please plan to replace new inverter depends on the load, ambient condition in advance.

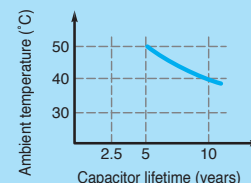

Precaution for Correct Usage

- Before use, be sure to read through the Instruction Manual to insure proper use of the inverter.
- Note that the inverter requires electrical wiring; a trained specialist should carry out the wiring.
- The inverter in this catalog is designed for general industrial applications. For special applications in fields such as aircraft, outer space, nuclear power, electrical power, transport vehicles, clinics, and underwater equipment, please consult with us in advance.
- For application in a facility where human life is involved or serious injury may occur, be sure to provide safety devices to avoid any accident.
- The inverter is intended for use with a three-phase AC motor. For use with a load other than this, please consult with us.

